



RESIDENTIAL SECTIONAL GARAGE DOOR INSTALLATION INSTRUCTIONS

READ THIS MANUAL CAREFULLY AND OBSERVE ALL WARNINGS WHEN INSTALLING, OPERATING OR MAINTAINING YOUR GARAGE DOOR.

Contents

- Safety Information 2
- How to Use these Instructions 3
- General Notes, Tools Needed 4
- Key Drawing (Door with Torsion Springs) 5
- Key Drawing (Door with Extension Springs) 6
- Removing Existing Door 7
- Preparing the Opening 9
- Truss Strap and Strut Installation 10
- Door Section Assembly 12
- Door Section Installation 15
- Lock Installation 16
- Track Assembly and Installation 17
- Track Assembly Completion Check List 20
- Counterbalance Installation (Extension Springs) 21
- Counterbalance Installation (Tension Springs) 23
- Final Adjustments 27
- Armortite Installation 28-33
- Warranty 34

L. J. King
7-18-05

! WARNING

Garage doors are large, heavy objects that move with the help of springs under high tension and electric motors. Since moving objects, springs under tension, and electric motors can cause injuries, your safety and the safety of others depend on you reading the information in this manual. If you have questions or do not understand the information presented, call your nearest service representative.

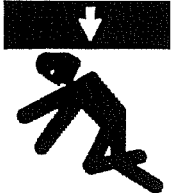
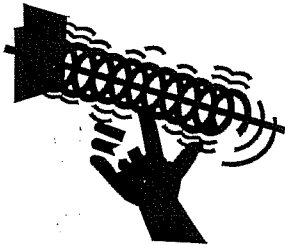
POTENTIAL HAZARD	EFFECT	PREVENTION
 <p>MOVING DOOR</p>	<p>Can Cause Serious Injury or Death</p>	<p>Get help or use support when removing old door and lifting new door into place. Keep people clear of opening while door is moving. Do Not place fingers or hands between sections. Use handles and step plates for manual operation.</p>
 <p>HIGH SPRING TENSION</p>	<p>Can Cause Serious Injury</p>	<p>Do Not try to remove, repair or adjust springs or anything to which door spring parts are fastened, such as, wood blocks, steel brackets, cables or other like items.</p> <p>Installation, repairs and adjustments must be done by a trained technician or a person with good mechanical skill using proper tools and instructions.</p>

SAFETY INSTRUCTIONS

<p>Removing Old Door</p> <ol style="list-style-type: none"> 1. Have trained technician remove torsion springs from door. 2. Get help to remove heavy door panels. 3. Do Not reuse old track. <p>Before Installation</p> <ol style="list-style-type: none"> 1. Read manual and warnings carefully. 2. Get tools and materials ready. 	<p>Installing New Door</p> <ol style="list-style-type: none"> 1. Get Help to lift and hold heavy door panels. <p>Installing Extension Springs</p> <ol style="list-style-type: none"> 1. Before raising door: <ul style="list-style-type: none"> • Check distance between tracks. • Put bolts in track ends to stop door. • Get help to raise door. • Use clamps or locking pliers to hold door up. 	<p>Installing Torsion Spring(s)</p> <ol style="list-style-type: none"> 1. Read, understand, and follow instructions. 2. Wear safety goggles. 3. Use two solid steel winding bars (1/2" x 18"). 4. Sound footing is required. 5. Do not remove a winding bar until second bar is in place and holding spring load.
---	---	---

In the following text, the words Warning and Caution emphasize important Safety Information:

WARNING means that serious injury or death can result from failure to follow instructions.

CAUTION means that minor injury or property damage can result from failure to follow instructions.

NOTE means that special attention should be given to the instruction.

INSTALLATION INSTRUCTIONS

HOW TO USE THESE INSTRUCTIONS

These instructions have been designed to aid the "Do-it-Yourself" Craftsperson when installing a Residential Sectional Garage Door. A "Do-it-Yourself" Craftsperson should have the tools necessary for this installation and be skilled in their use. It is very important that you read and understand these instructions and **WARNINGS** before attempting to install your door. If you do not understand an instruction or have a question, call your nearest service representative.

1. Use "KEY DRAWINGS" on pages 5 and 6 to locate and identify specific terminology.
2. These instructions show the step-by-step procedures required to install the following:

DOORS

Wood - 104, 126, 151, 153,
159, 201, 204

Steel Panel - 188, 281, 288, 381,
391, 399

TRACK

Standard 2" residential

COUNTERBALANCE SPRINGS

Extension

Torsion

Use only those instructions applicable to your particular installation.

3. Each "STEP" will include:
 - a. A brief statement of the procedure to be performed.
 - b. Illustrations showing procedure in specific detail.
 - c. Hardware and fasteners required.

DOOR OPENING REQUIREMENTS

1. Jambs should be plumb.
2. Floor should be flat and level.
3. Opening should be the same width as the length of the door section.
4. Minimum headroom - 12"
5. Minimum sideroom - 3 1/4"
6. MASONRY WALLS:
HEADER - should be cased with a wood 2 x 4 or 2 x 6.
JAMB - should be cased with wood 2 x 4's or 2 x 6's which extend 12" above header.

NOTE: Casings should be flush with opening and secured with masonry anchors.

PROTECTION AND CARE OF WOOD DOORS

It is important that this door be adequately protected from the weather. Do not allow door to absorb moisture before painting. Prior to or immediately after installation this door should be primed inside, outside and on all edges. Finish with two (2) coats of high quality, exterior, alkyd oil base enamel on all surfaces. Solid color stains, if required, should be applied in addition to the above requirements. Stain, varnish or natural finishes do not offer adequate protection. Protection of the door is your responsibility and not the responsibility of the supplier.

DEFINITIONS OF TERMS USED

HEADROOM - distance from top of door opening to ceiling.

SIDEROOM - distance from side of door opening to sidewall.

PLUMB - perpendicular to floor of structure. Measured with a plumb line.

CASE - attachment of wood 2 x 4's or 2 x 6's around the inside face (header & jambs) of door opening on masonry walls.

CLINCH NAIL - #16 framing nail driven into door jambs and bent 90° over ends of door sections to temporarily hold door sections in mounting position. See General Note 4, page 4.

CLEARANCE HOLE - hole drilled through material and large enough to allow easy passage of a bolt or fastener being used.

PILOT HOLE - predrilled hole in material in which a screw is used. May be step to obtaining larger hole in thin material.

GENERAL NOTES

1. Nuts, bolts and screws should be hand tightened to prevent thread stripping.

NOTE: Use care with power tool on steel door, do not exceed 100 in/lbs of torque.

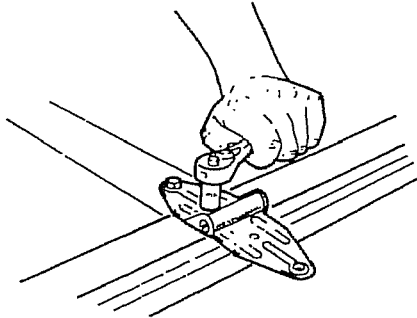

2. All required items are furnished except those noted. Additionally you will need:

- 2x4 or 2x6 wood framing material.
- Ten (10) #16 framing nails.
- Stop molding.
- Hanging angle (see Page 17).
- Lag screws for attaching ceiling angle to ceiling joists.
- 1/4" hex bolts, nuts & lockwashers used to secure hanging angles, sway braces & track.
- Bottom weatherseal for Wood Doors.

3. Stop molding (not furnished) is required to correctly install this door. It must be installed inside door opening on jambs and header.

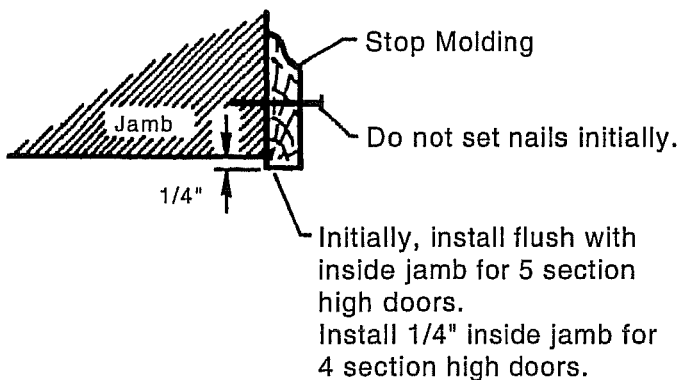

4. When stacking door sections in mounting position on door opening, temporarily "CLINCH NAIL" sections to jambs. Drive a #16 framing nail securely into jamb. Carefully bend nail over end of section. Do not damage door section.

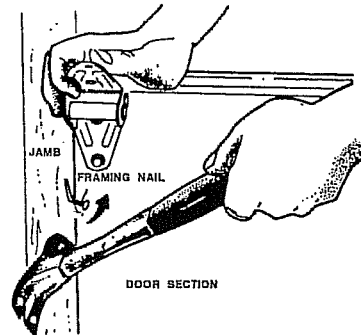

5. Hanging angle shown in details on pages 17, 19, 21, 22, and 26 is not supplied with your door. You will need approximately 6 feet of hanging angle to complete this project.

TOOLS NEEDED

You will need the following tools to perform this installation:

- Safety Glasses
- Tape Measure
- Stud Finder

Electric Drill and Bits



Carpenter Level



Step Ladder



Saw Horses



Hack Saw



Locking Pliers (2)



Hammer



Slotted Screwdriver



Wrenches



* Winding Bars

(Two - 1/2" x 18" long steel rods)
for Torsion Spring Counterbalance only,
included with Pre-packed Door.



KEY DRAWING

NOTES

- ① Top rails, bottom rails, center stiles and end stiles on Insulated Doors and Flush wood doors are not visible as shown, but do exist.
- ② Step-Lift handles must be mounted on bottom rail at any center stile.
- ③ Lock mounting hole locations will vary according to size and type of door.
- ④ Lift handles must be mounted vertically on any center stile on lock section, but must clear lock and/or strut and be directly above step lift handle.
- ⑤ Ceiling joists shown run parallel to header. Some structures have joists that run parallel to sidewall.
- ⑥ Bottom sections of Wood doors are not supplied with weatherseals. Weatherseals must be purchased separately and installed using small nails or a staple gun. Bottom sections of Steel doors are supplied with weatherseal installed.
- ⑦ Warning labels are placed on each side, about 5' from the floor.
- ⑧ Bottom bracket warnings are placed on each side adjacent to the bracket position. Do not paint over or cover labels.

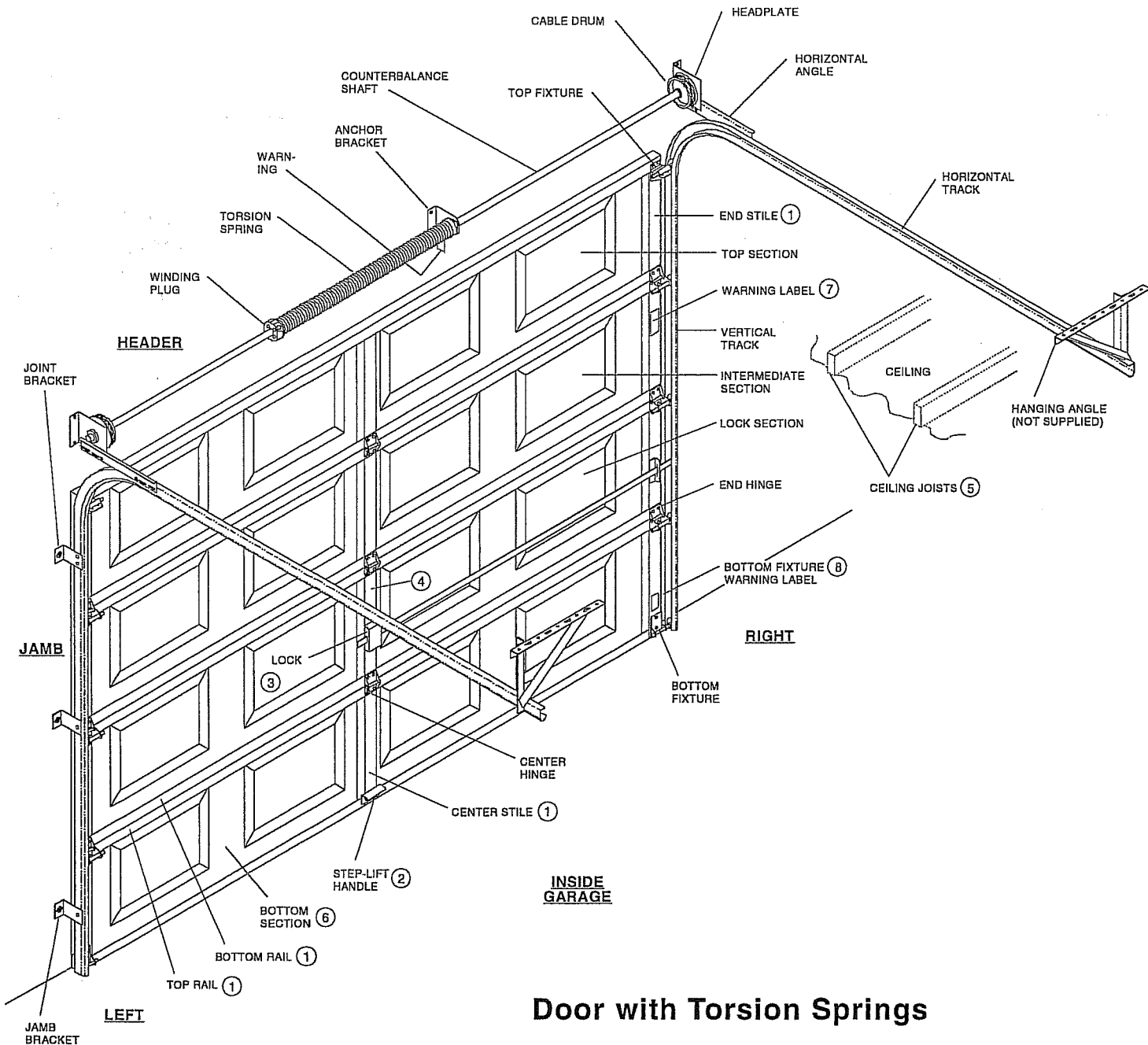
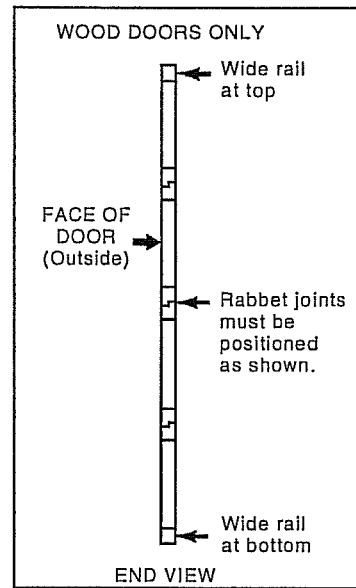

Door with Torsion Springs

KEY DRAWING

NOTES

- ① Top rails, bottom rails, center stiles and end stiles on Insulated Doors and Flush wood doors are not visible as shown, but do exist.
- ② Step-Lift handles must be mounted on bottom rail at any center stile.
- ③ Lock mounting hole locations will vary according to size and type of door.
- ④ Lift handles must be mounted vertically on any center stile on lock section, but must clear lock and/or strut and be directly above steplift handle.
- ⑤ Ceiling joists shown run parallel to header. Some structures have joists that run parallel to sidewall.
- ⑥ Bottom sections of Wood doors are not supplied with weatherseals. Weatherseals must be purchased separately and installed using small nails or a staple gun. Bottom sections of Steel doors are supplied with weatherseal installed.
- ⑦ Warning labels are placed on each side, about 5' from the floor.
- ⑧ Bottom bracket warnings are placed on each side adjacent to the bracket position. Do not paint over or cover labels.

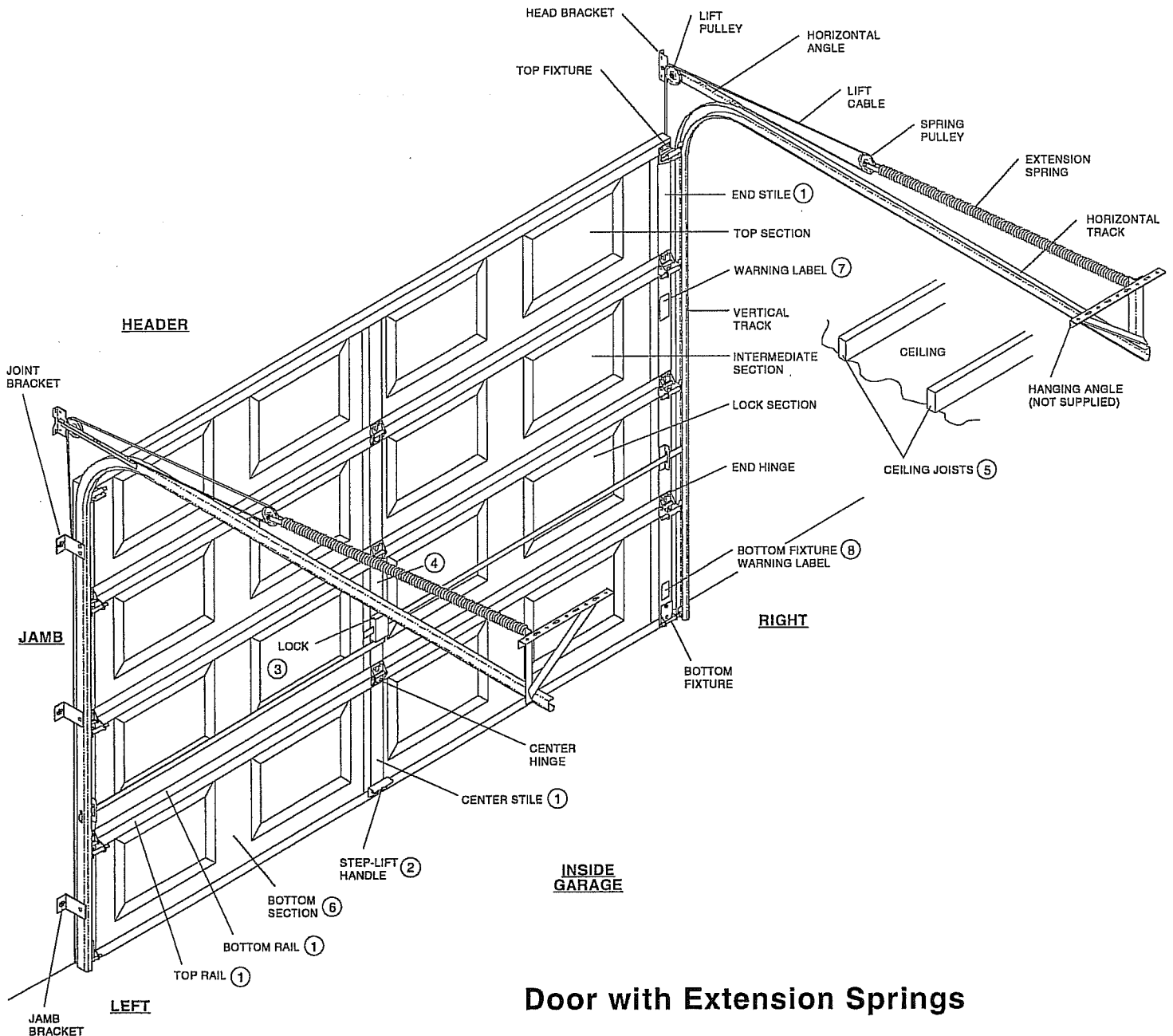
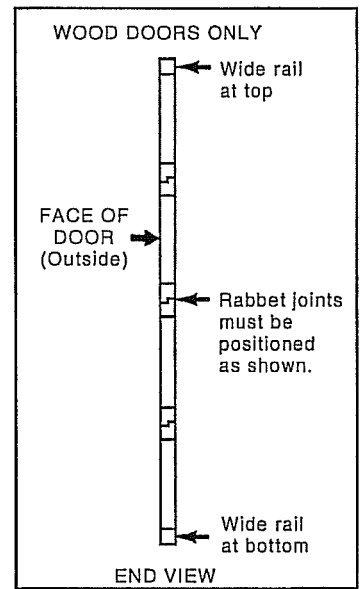

Door with Extension Springs

REMOVING THE EXISTING DOOR

The first and most important step in removing an existing door is to release spring tension which counterbalances the weight of the door. Generally there are two types of springs used to help move the door - "torsion springs" and "extension springs". Refer to the Key Drawings on pages 5 and 6 to see which type of springs your old door has.

⚠ WARNING

DO NOT try to remove doors with **TORSION SPRINGS**. Have a trained technician remove the torsion spring and the attached cables and hardware from the door.

Attempting to remove a torsion spring assembly without proper training or tools may result in an uncontrolled release of spring forces which can cause serious injury.

REMOVING EXTENSION SPRINGS

Extension springs are shown installed on a sectional garage door in the Key Drawing on page 6. Instructions for removing this type of spring are given below. If your door has springs that are different from the extension springs shown on page 6, have a trained technician release the spring tension for you.

⚠ WARNING

Raise the door to release spring tension before attempting to remove the door.

Do not attempt to remove or adjust springs with door in the down position. Use locking pliers or "C" clamps to keep the door from moving or falling once the springs are removed.

STEP 1

Removing Extension Springs

- Raise the door to the full open position.
- Install locking pliers or "C" clamps to flat portion of track on both sides just below door to prevent door from closing.
- With the door fully open, most spring tension has been removed.

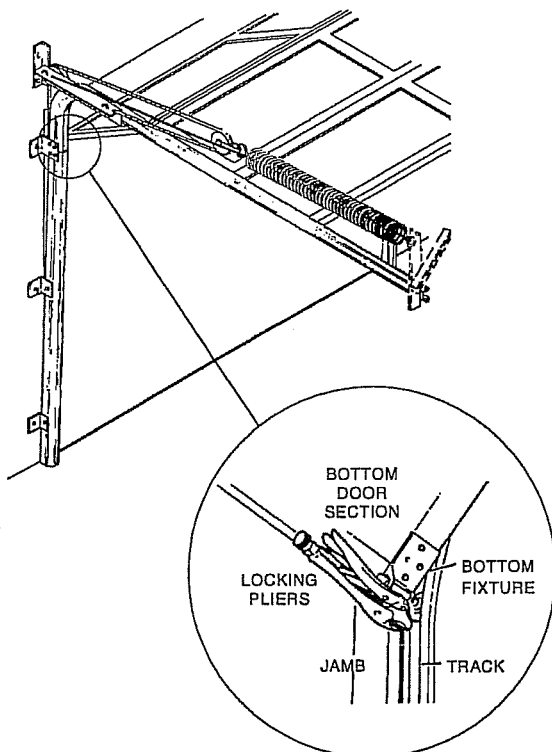

STEP 2

- Detach the lift cables at both ends. Disassemble and remove the springs and cables completely from the door.

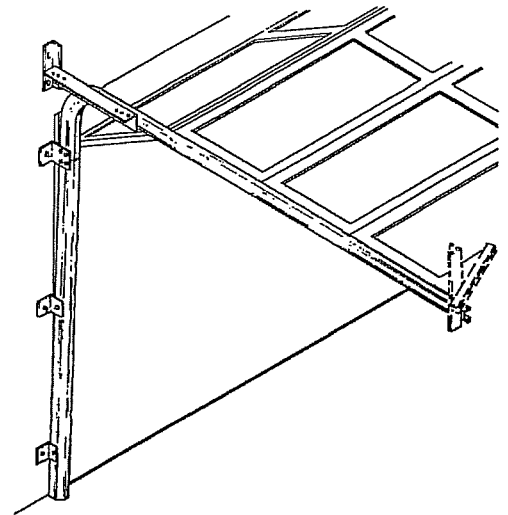

REMOVING THE EXISTING DOOR

STEP 3

- Remove the locking pliers or "C" clamps from the track and carefully close the door.

WARNING

Use two or more helpers to assist you in lowering the door.

Some large wood doors might weigh as much as 400 pounds when the spring tension is removed. The weight of the door will not be apparent when you first begin to close the door. The door will feel progressively heavier as it is lowered until its full weight (as much as 400 pounds) is realized about one foot from the floor. A single car door may weigh as much as 140 pounds.

CAUTION

For personal safety, keep hands and fingers clear of section joints, track and other door parts while the door is opening and closing.

Wooden blocks should be placed underneath the door when closing to prevent fingers from being trapped.

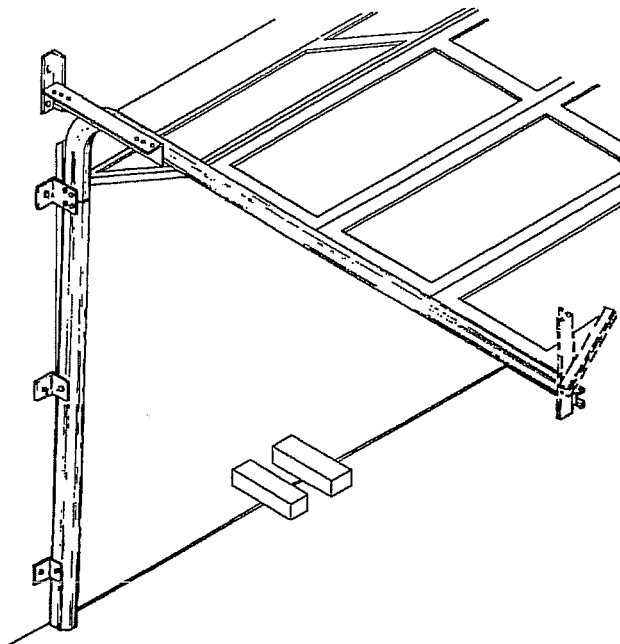

STEP 4

- The door can now be disassembled. Starting with the top section, remove the hardware and unstack the sections one at a time.

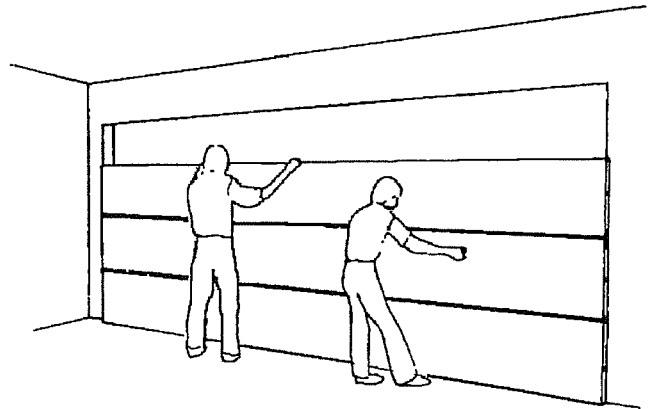

STEP 5

- After all sections have been removed from the opening, remove all remaining track and hardware from the jambs. The hangers that attach the rear ends of the overhead track could be left for reuse on the new door.

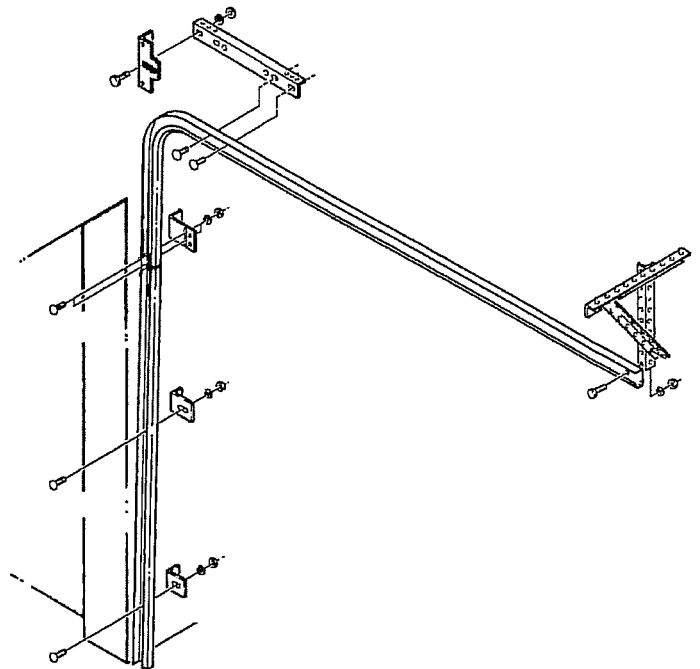

PREPARING THE OPENING

- On the inside of the garage the door opening should be framed with wood jambs, 2 x 4's or 2 x 6's. The jambs should extend 12 inches above the header. If you have just removed an old door, the jambs should be inspected for the condition of the wood. If the wood is rotten it should be replaced now. The jambs should be plumb and the header level. If there are any bolts fastening the jambs to the wall, the heads should be flush so they don't interfere with the installation of the new door.
- **NOTE:** Opening width = Door Size

⚠ WARNING TORSION SPRINGS

If the door has a torsion spring assembly, **YOU MUST MAKE SURE THAT THE TORSION SPRING ANCHOR BRACKET WILL BE SECURELY FASTENED TO THE GARAGE WALL.** Anchor into wood stud or structurally sound member. Failure to securely fasten the anchor bracket could allow the springs to break loose from the garage wall and cause severe personal injury.

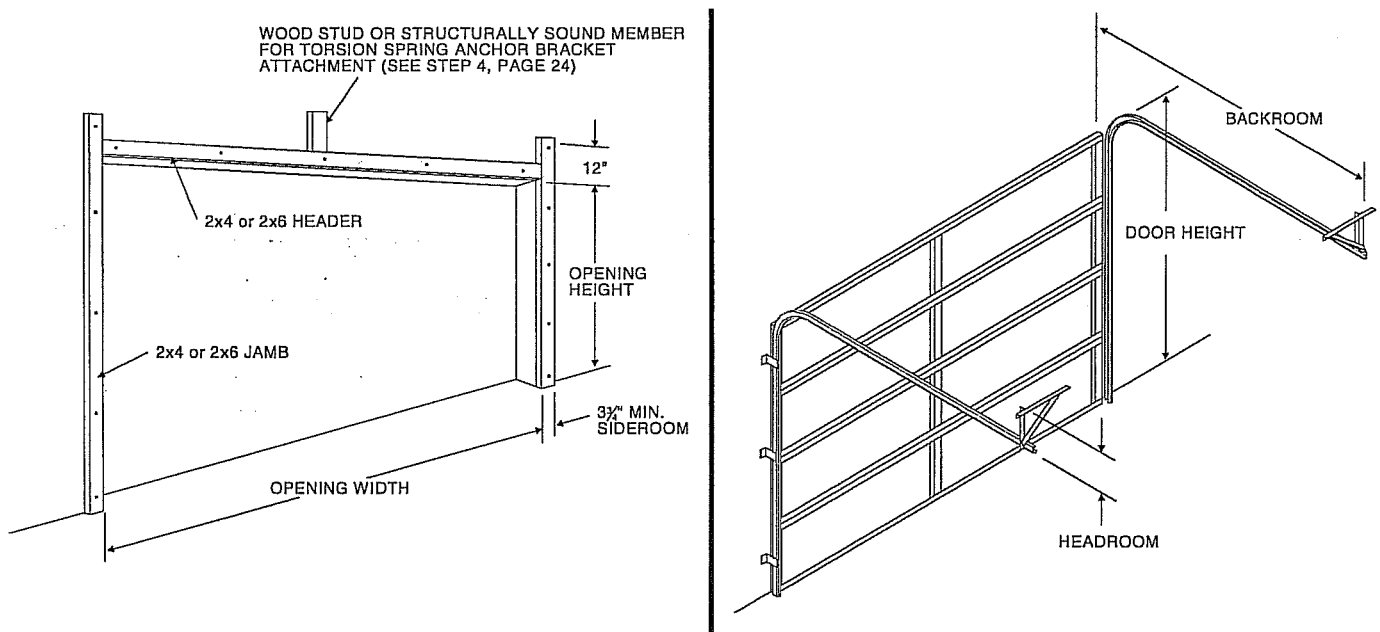

Check Headroom

- Headroom is the space needed above the top of the door opening for the door, the overhead tracks and the springs. Measure to check that there are no obstructions in your garage within that space. The minimum headroom space requirement is 12 inches.
- The backroom distance is measured from the back of the door into the garage, and should be at least 1½ feet more than the height of the opening.
- A minimum sideroom of 3¾ inches should be available on each side of the door.

NOTE: About three inches of additional headroom height at the center plus additional backroom is needed to install an automatic garage door opener. Check door opener instructions.

Low Headroom

If you have restricted headroom, several remedies are available. Contact your nearest Overhead Door dealer for correct product.

- Door stop molding should be temporarily nailed to the edges of the jambs (see General Note 3, page 4).

TRUSS STRAP AND STRUT INSTALLATION

While working on door sections, lay sections flat on sawhorses. Position sawhorses approximately 2-3 ft. from ends. **DO NOT LAY SECTIONS FLAT WHEN SUPPORTED ONLY AT ENDS.**

NOTE: Steel door sections, 16 and 18 ft. long, must be carried vertically (on edge).

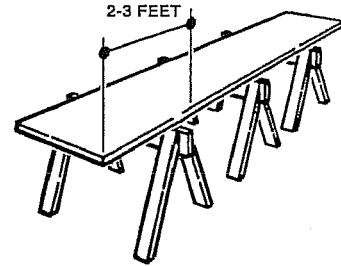

TRUSS STRAP INSTALLATION - 16 FT. TO 18 FT. WOOD PANEL

- Install truss straps on bottom section only, before installing struts.
- Truss straps are located beneath bottom section struts.
- Position straps as shown.
NOTE: Strap must connect top and bottom rails of bottom section.
- Using holes in straps as a guide, drill $\frac{1}{8}$ " diameter pilot holes $\frac{3}{4}$ " deep in top and bottom rails.
- Secure straps to door section with lag screws.

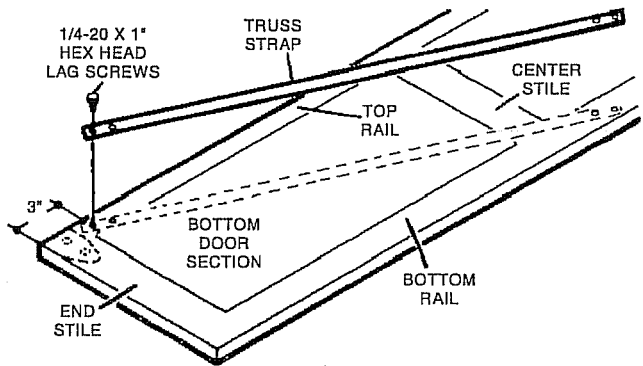

STRUT INSTALLATION - WOOD DOORS

- Struts are to be installed on bottom, lock, and top sections (12 ft.-18 ft. flush doors and 15 ft.-18 ft. panel doors). Strut top and bottom sections only on 8 ft. - 10 ft. flush doors.
- Using holes in end of strut as guides, drill $\frac{1}{4}$ " diameter clearance holes in end stiles.
- Attach ends of strut to end stiles with $\frac{1}{4}$ -20 x $1\frac{3}{4}$ " carriage bolts, lock washers, and $\frac{1}{4}$ -20 nuts.
- Drill $\frac{1}{8}$ " diameter pilot holes in remaining stiles at strut holes.
- Secure strut to center stiles with $\frac{1}{4}$ " x 1" lag screws.

STRUT LOCATIONS

FLUSH DOORS

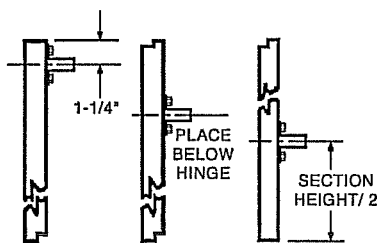

PANEL DOORS

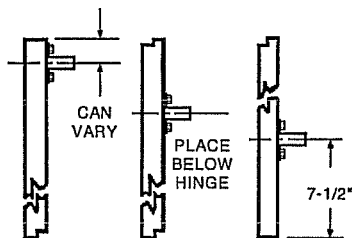

TOP LOCK BOTTOM

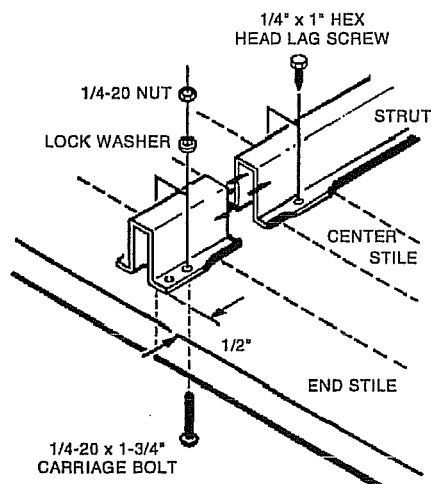

STRUT INSTALLATION - 16 FT. AND 18 FT. STEEL

- Struts are to be installed on bottom, lock, and top sections on 18 ft. doors.
- Strut is attached to top section only on 16 ft. doors. Struts on lock and bottom sections are optional.
- Install two (2) self-extruding screws at each end and center stile at top rail of top section.
- Using holes in end of strut as guides, drill 1/8" diameter pilot holes in end stiles.
- Attach ends of strut to end stiles with 1/4-14 x 5/8" self-extruding screws.
- Drill 1/8" diameter pilot holes in remaining stiles at strut holes.
- Secure strut to stiles with 1/4-14 x 5/8" self-extruding screws.

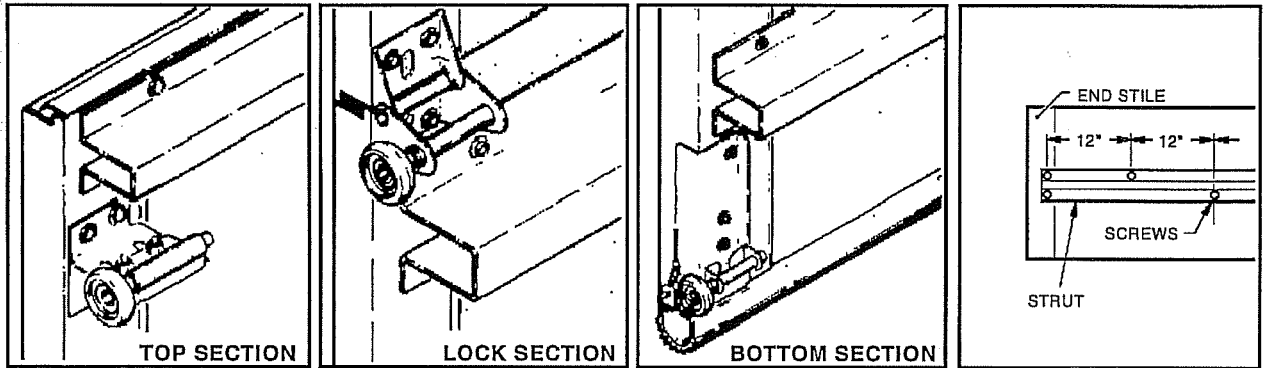
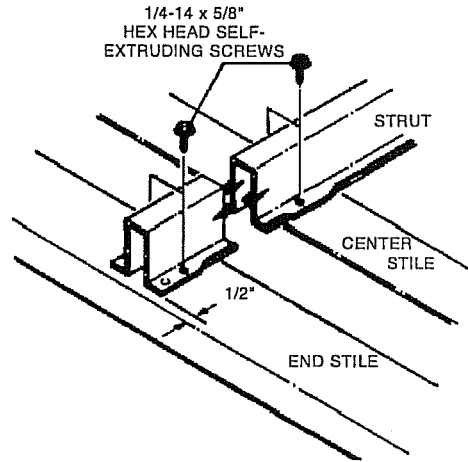
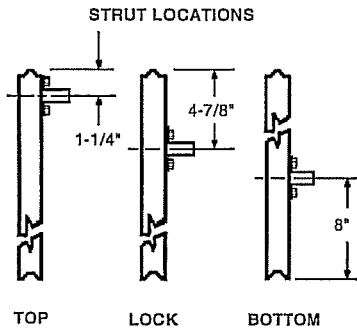

STEP 1

BOTTOM SECTION

- Secure lift cables to bottom fixture.
- Hold bottom fixture in mounting position.
- Using bottom fixture as a guide, drill 1/4" diameter clearance holes thru door.

WOOD

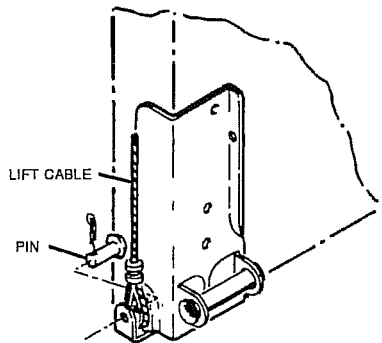

STEP 2

BOTTOM SECTION

- Secure bottom fixtures to door.
- Install track rollers.

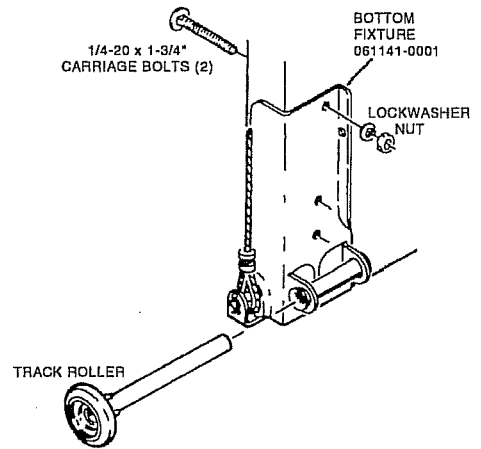

- Secure lift cables to bottom fixture.
- Install extruding screws in bottom fixture.
- Install two (2) extruding screws at each center stile on bottom rail (180/280/390 Series ONLY).

STEEL

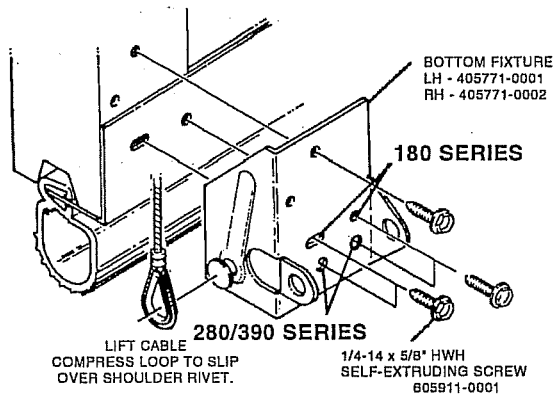

- Install track rollers.

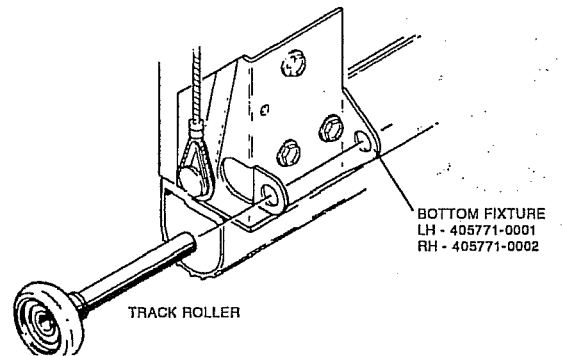

STEP 3

BOTTOM SECTION

- Using step-lift handle as a guide, drill two 5/16" diameter clearance holes through bottom rail. Secure handles to door.

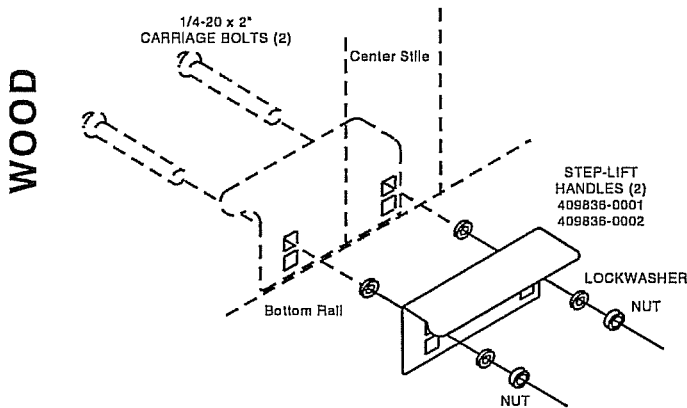

WOOD

STEP 4

ALL EXCEPT TOP SECTION

- Install end hinges at top of each end stile on each section. Do not secure fasteners completely.
- Install track rollers.

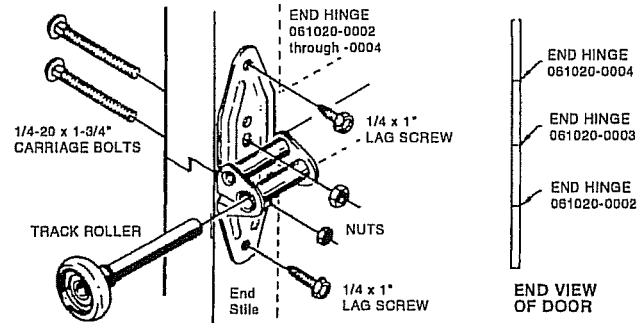

- After door sections have been installed in opening, secure upper hinge halves to next higher section and secure all fasteners.

- Install Step-lift Handle Kit on Insulated doors according to instructions below. For Non-insulated doors see instructions on page 15. At or near center stile where lock is located:

- Drill two (2) 1/4" diameter holes through door using holes in step-lift handle as a guide. (Use upper holes for Series 180 doors; lower holes for Series 280 doors).
- Drill two (2) 1/2" diameter holes through inside of door only using 1/4" diameter holes as a pilot.
- Insert carriage bolts through outside handle and door.
- Slide spacers over carriage bolts from inside.
- Secure handles to door with lockwashers and nuts.

STEEL UNINSULATED

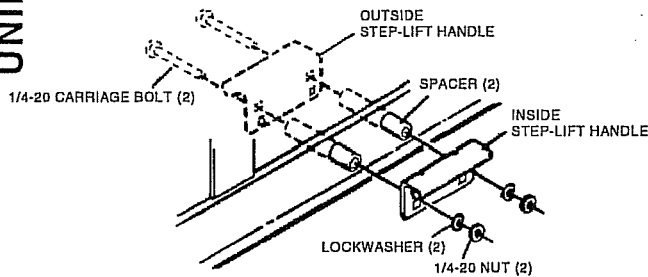

- Install end hinges at top of each end stile on each section. Do not secure fasteners completely.
- Install track rollers.

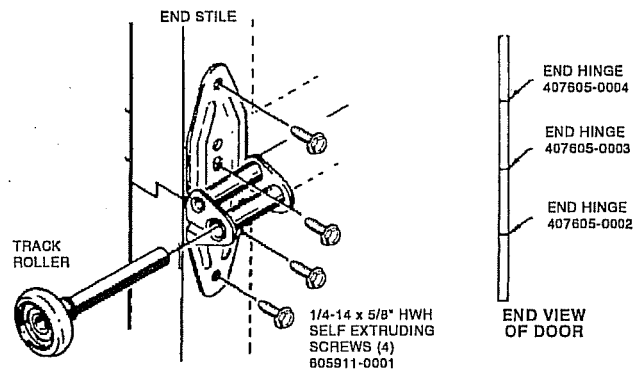

- After door sections have been installed in opening, secure upper hinge halves to next

STEP 5

WOOD

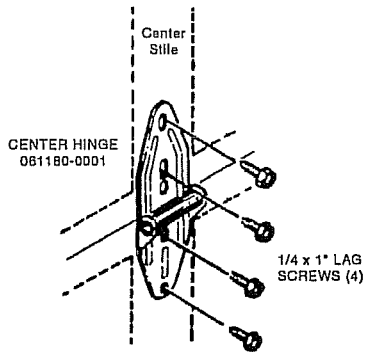

- After door sections have been installed in opening, secure upper hinge halves to next higher section and secure all fasteners.

- Install center hinges at top of each center stile on each section. Do not secure fasteners completely.

STEEL
UNINSULATED

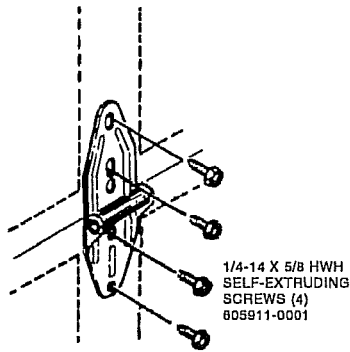

- After door sections have been installed in opening, secure upper hinge halves to next higher section and secure all fasteners.

STEP 6

LOCK SECTION

- Install lift handle (when provided).

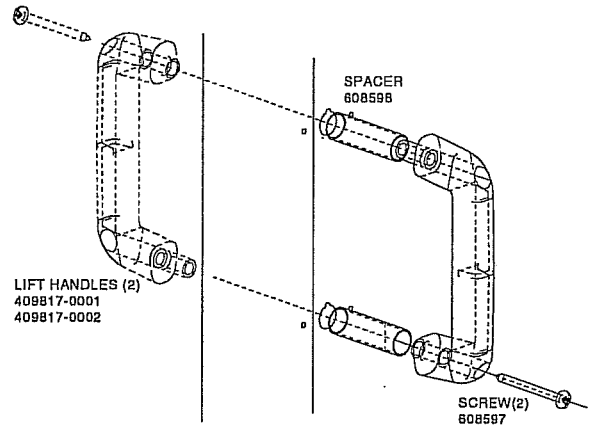

- Install lift handles

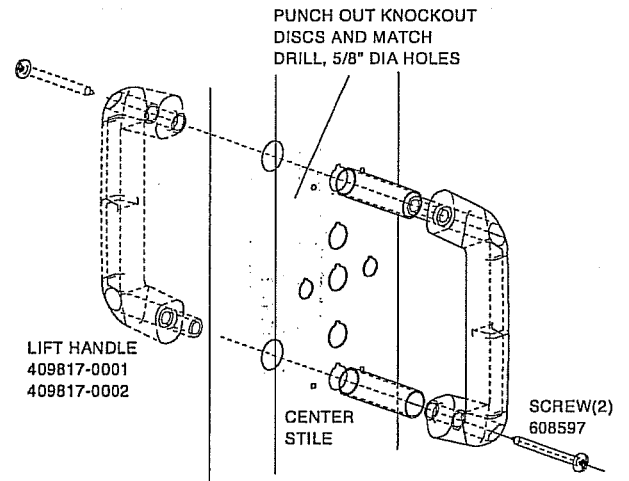

STEP 7

LOCK SECTION

- Install Lock, if supplied.

See LOCK INSTALLATION INSTRUCTIONS on Page 16.

ALTERNATE STEP 3
FOR STEEL DOORS

BOTTOM SECTION

Step-Plate Installation Instruction for Series 180 & 280 Non-insulated steel doors

- The Step-Plate should be positioned below the Handle Assy.
- Slip the Step-Plate between the Back Rail and the Door Section.
- Using the Step Lift Handle as a guide, drill two 1/4" holes thru Door Section.
- Insert 1/4-20 x 1/2" bolts thru the Lift Handles. Secure with 1/4" Lock Washers and Cap Nuts.

STEP 8

ALL SECTIONS

- Install Stop Mold (See General Note 3, page 4).
- Center and level bottom section in doorway.
- Clinch nail bottom section to jambs (See General Note 4, page 4).

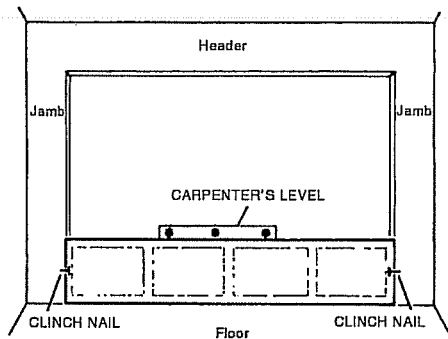

- Stack Bottom, Lock, and Intermediate Sections in doorway.
- Clinch nail all sections to jambs.

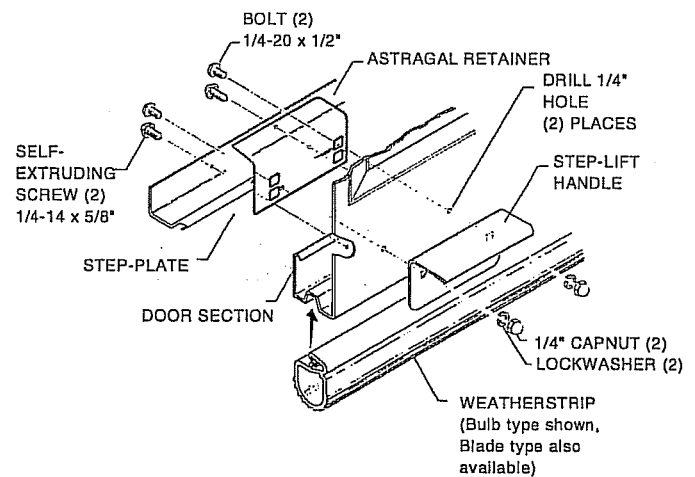
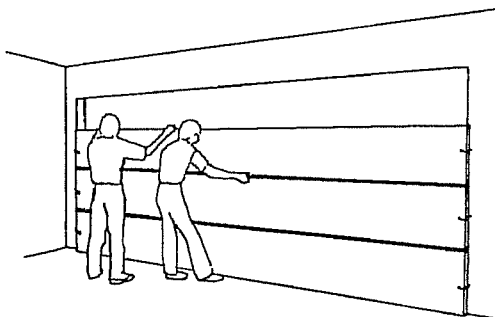

STEP-PLATE INSTALLATION
Series 180 & 280 Panel Shown

STEP 9

ALL SECTIONS

- Secure upper hinge halves to next higher section and secure all fasteners.

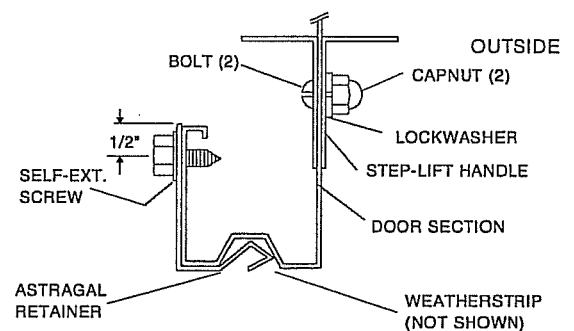

ASSEMBLED VIEW

LOCK INSTALLATION INSTRUCTIONS (PREVIOUS STEP 7)

LOCK INSTALLATION

CAUTION

If electric operator is installed later, lock should be made inoperative.

Lock Kits are pre-packaged with the specific hardware and fasteners required for the various types of doors.

Lock installation, on all types of doors, is very much the same procedure.

Variations generally occur in the type of fasteners used.

Lock handle assembly may be mounted in one of two (2) ways:

- (A) Handle assembly positioned as shown in Figure 1 where lockcase bar will have to be moved to right (locked).
- (B) Handle assembly mounted with handle held up in unlocked position. NOTE: Masking tape may be helpful to hold handle, screws and lock escutcheon to section while attaching lockcase.
- (C) If lock is not installed, cover outside lock holes with blank escutcheon.

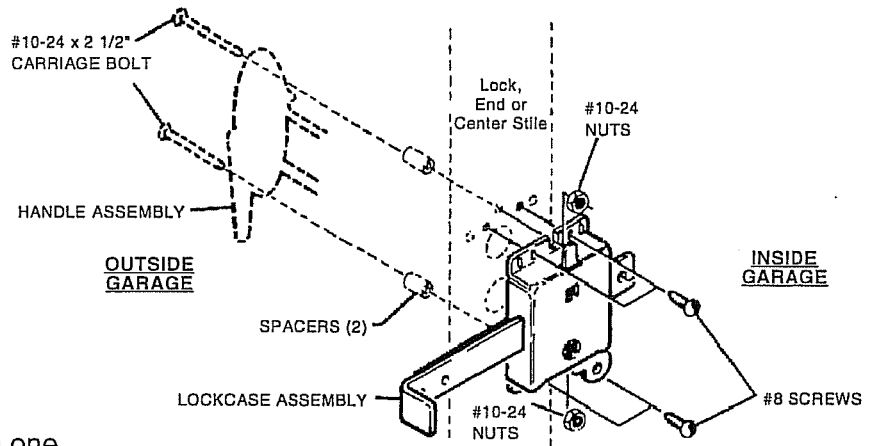
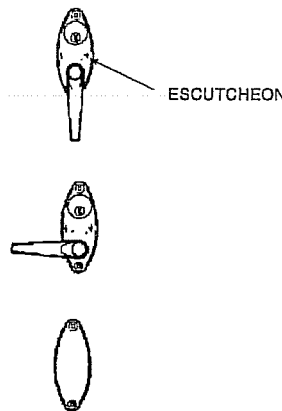
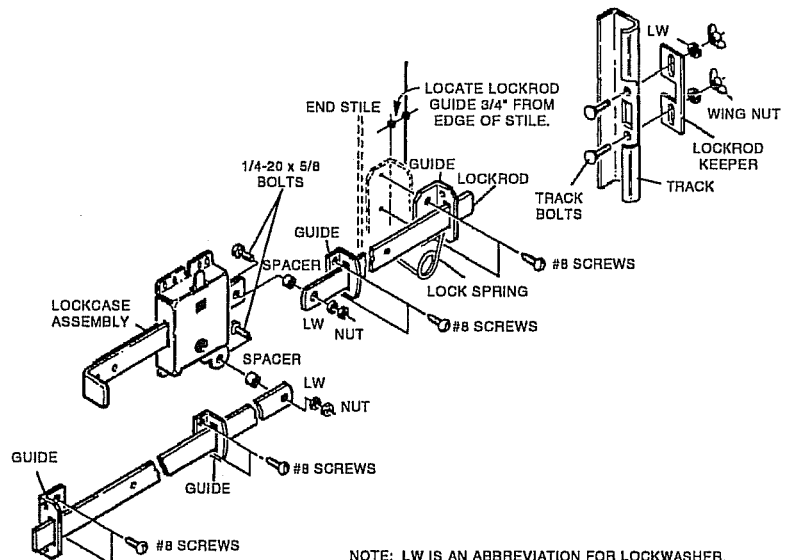
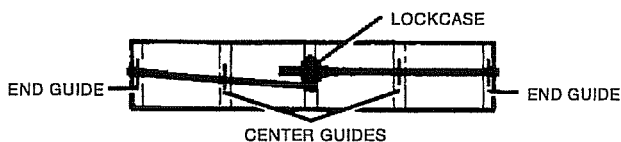

Figure 1



LOCKROD INSTALLATION

- Secure lockrod(s) to lockcase assembly.
- Install guide(s) on lockrod(s).
- Position guide(s) on end stile(s). Align with slots in track.
- Drill mounting holes in end stile(s) per fastener requirements.
- Secure guide(s) to end stile(s).
- If applicable, locate guides on center stiles as shown below.



NOTE: LW IS AN ABBREVIATION FOR LOCKWASHER.

- Drill mounting holes per fastener requirements and secure guides to center stiles.
- If required, install lockrod keeper(s) on slot in track(s).
- Install lock spring. Locate on left hand side on double rod installation.

TRACK ASSEMBLY

- The drawing below shows all track components and assembly hardware for residential track with extension spring and torsion spring counterbalance headplates and brackets.
- Follow the step sequence for assembly and installation.

NOTE: LW IS AN ABBREVIATION FOR LOCKWASHER.

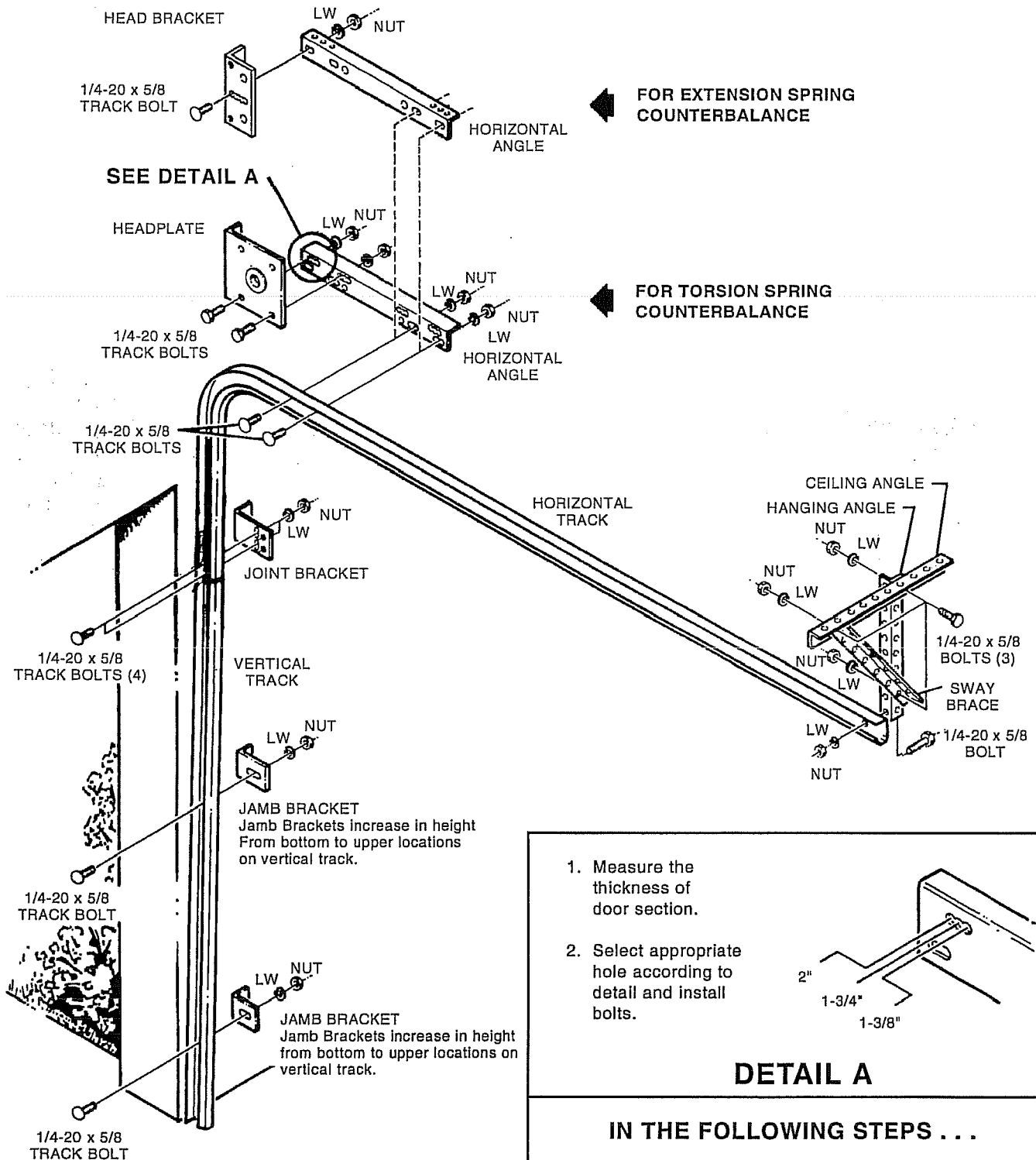

1. Measure the thickness of door section.
2. Select appropriate hole according to detail and install bolts.

DETAIL A

IN THE FOLLOWING STEPS . . .

WHERE "LAG SCREWS" ARE CALLED OUT, USE THE 5/16" x 1-3/4" LAG SCREWS SUPPLIED UNLESS OTHERWISE INDICATED.

TRACK ASSEMBLY

STEP 1

- Secure joint brackets to vertical tracks using track bolts.
- Install bottom and center jamb brackets on vertical tracks using track bolts.
(See Page 17)

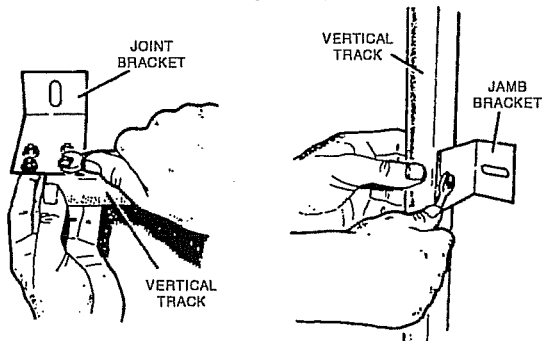

STEP 4

- Secure headplates or head brackets to horizontal angles using track bolts for headplates and hex head bolts for head brackets. See Track Assembly Drawing - Detail A, Page 17.

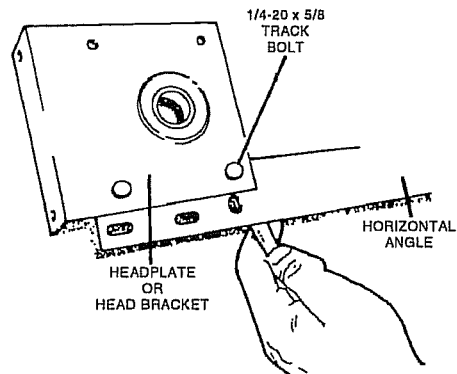

STEP 2

NOTE: When positioning vertical tracks over track rollers, track must be spaced 1/2" away from end of door as shown in detail below.

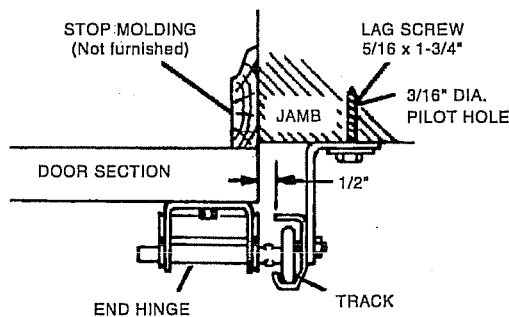

STEP 5

- Secure horizontal angles to horizontal track using track bolts.
- Install bolts from inside of track. DO NOT tighten.
(See Page 17)

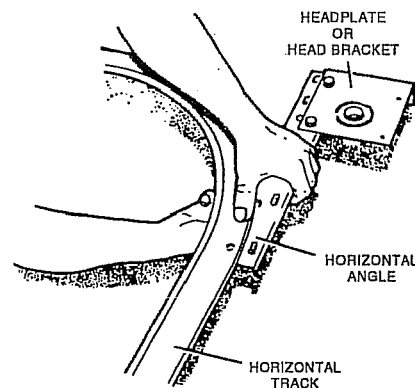

STEP 3

- Position vertical tracks over track rollers.
- Adjust vertical track(s), as required, to match leveling of bottom section.
- Secure joint brackets and jamb brackets to jambs using lag screws.

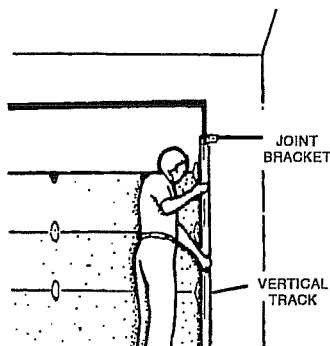

STEP 6

- Install horizontal track by supporting rear of track with temporary hanger. Secure horizontal track to joint brackets.
- Align headplates or head brackets with vertical tracks and secure to header using lag screws.

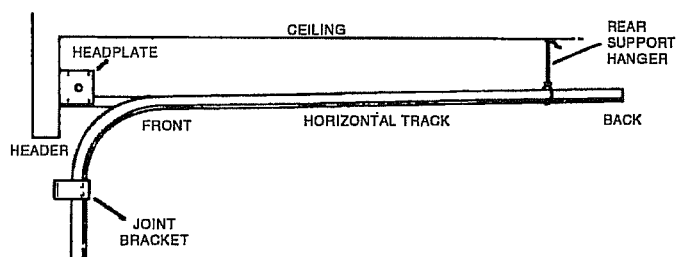

TRACK ASSEMBLY

STEP 7

- Install top section.
Install track rollers in top fixtures.
- Hook track roller/top fixture into track.
- Install top fixtures.
On 180/280 Series steel doors, install (2) self-extruding screws on the top rail at each end and center stile.

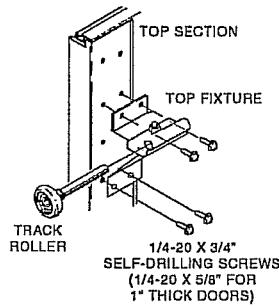
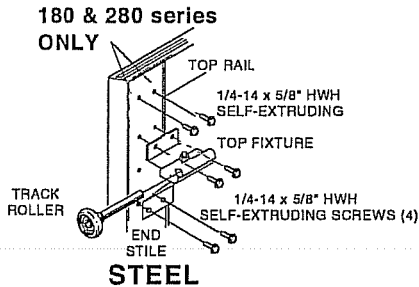
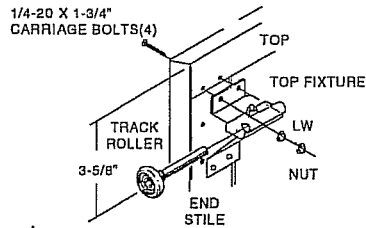

STEEL

THERMACORE

STEP 8

- Secure pull rope (if supplied) to bottom fixture and at eyebolt.

⚠ WARNING

Remove Rope if Electric Operator is to be used.

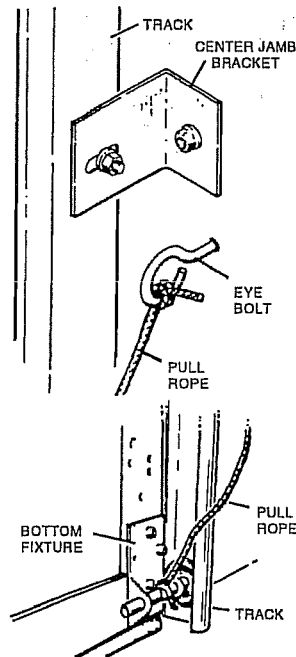
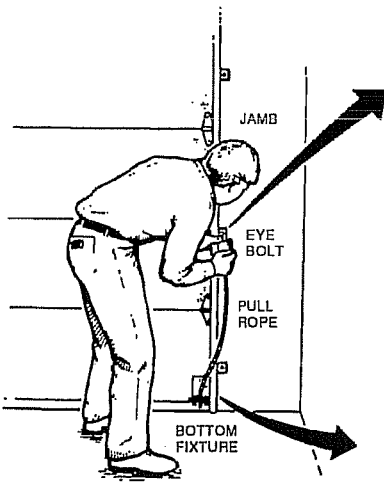

STEP 9

- Route lift cables up ends of door sections and over joint brackets.
- Remove all clinch nails. Make sure horizontal tracks are parallel and perpendicular to the wall.

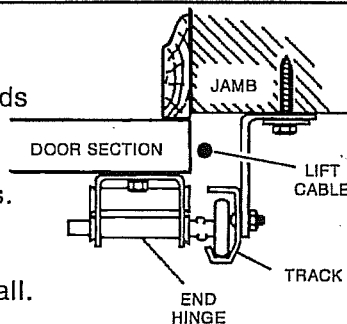

STEP 10

- Using a stud finder, locate ceiling joists nearest rear end of horizontal tracks.
NOTE: The "KEY DRAWING" should help to locate ceiling joists.
- Cut two 24" lengths of perforated angle for ceiling angles (not supplied).

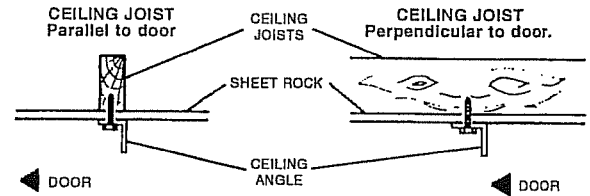

- Secure ceiling angles to ceiling joists using lag screws (not supplied).

STEP 11

- Measure distance from ceiling to horizontal tracks at front and rear.

NOTE: Rear of tracks should be elevated 1" higher than front. Tighten track bolts shown in Step 5.

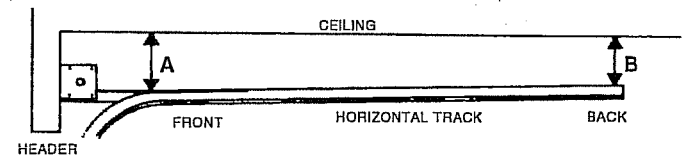

Dimension "B" should be 1" less than dimension "A".

STEP 12

- Cut vertical hanging angles to length required from perforated angle (not supplied).
- Secure hanging angles to ceiling angles and track using hex head bolts (not supplied). DO NOT install sway braces at this time.

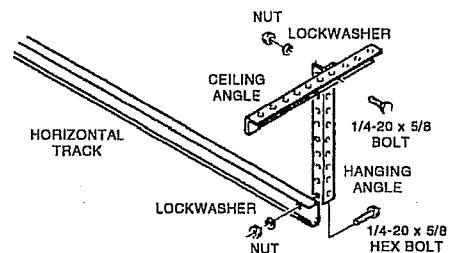

COMPLETION CHECK LIST

- Make sure all fasteners are secure at:
 - Bottom Fixtures
 - End Hinges
 - Center Hinges
 - Top Fixtures
 - Handles
 - Struts and Straps (if required)
 - Joint Brackets
 - Jamb Brackets
 - Hanging Angles
 - Ceiling Angles
 - Headplates or Head Brackets
 - Horizontal Angles
- Make sure lift cables are attached securely.
- Make sure all clinch nails are removed.

COUNTERBALANCE INSTALLATION

The following procedures cover the installation of Extension Spring and Torsion Spring counterbalance systems.

Follow only those instructions applicable to your specific installation.

If you are installing the Torsion Spring Counterbalance system, disregard Extension Spring Counterbalance and continue on Page 23.

EXTENSION SPRING COUNTERBALANCE ASSEMBLY

- The drawing at right shows all components required to install left side extension springs. Right side will be similar.
- Follow the step sequence for assembly, installation and adjustment.

The complete door must be raised into horizontal tracks before attaching lift cables to extension springs.

! WARNING

Falling door can cause serious injury.
Before attempting to raise door:

Check distance between tracks. If tracks are too far apart, door could fall.

Put long bolts through holes at end of each track to stop travel.

Get help to raise door. Door is very heavy.
Raise door slowly.

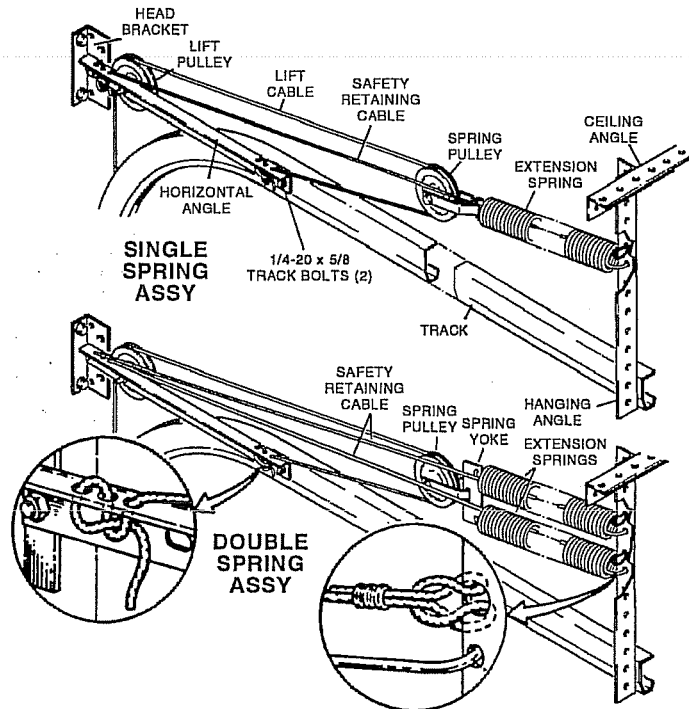

STEP 1

- Install lift pulleys on horizontal angles.

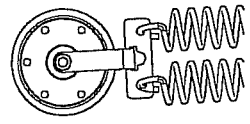
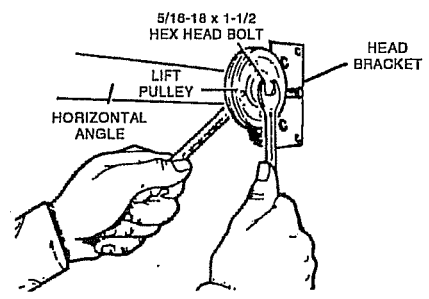

Double Spring Assy With Yoke

EXTENSION SPRING COUNTERBALANCE

STEP 2

- Raise door slowly. Watch top track rollers and horizontal tracks.
- Check spacing between ends of door and tracks. Maintain 1/2" clearance.
- If tracks are set too far apart, lower door and make necessary adjustments.
- Cut sway braces from perforated angle (not supplied) and install using hex head bolts (not supplied).

NOTE: LW IS AN ABBREVIATION FOR LOCKWASHER.

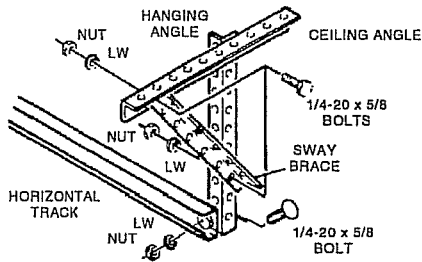

STEP 3

- Raise door and install locking pliers to flat portion of track just below door to prevent door from accidentally closing.

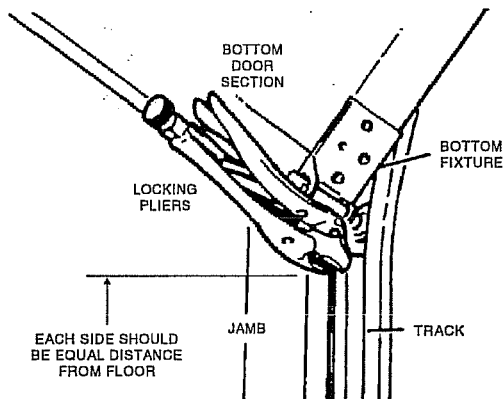

STEP 4

- Hook one end of each extension spring into each hanging angle.
- Install spring pulleys on opposite ends of springs.

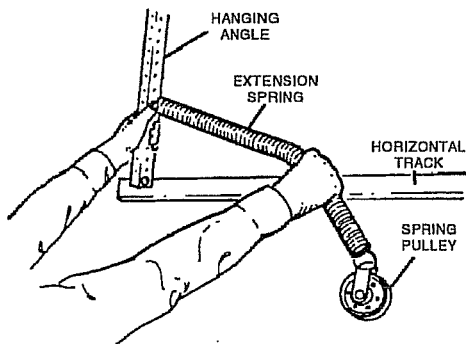

- For double extension spring installation, refer to Extension Spring Counterbalance Assembly Drawing.

STEP 5

NOTE: Proper installation of safety retainer cables is important. These cables help prevent personal injury or property damage by retaining the broken piece of the spring in cases of extension spring failure.

- Attach looped end of safety retainer cables to hanging angles and thread cables thru springs.
- Remove slack from retainer cables and secure to appropriate holes in horizontal angles.
- See Extension Spring Counterbalance Assembly Drawing, Page 21.

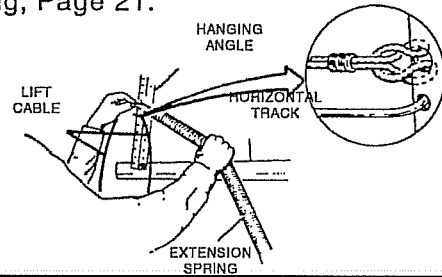

STEP 6

- Route lift cables over lift pulleys, around spring pulleys to holes in horizontal angles.
- Pull equal tension on both springs and secure lift cables to horizontal angles.
- See Extension Spring Counterbalance Assembly Drawing, Page 21.

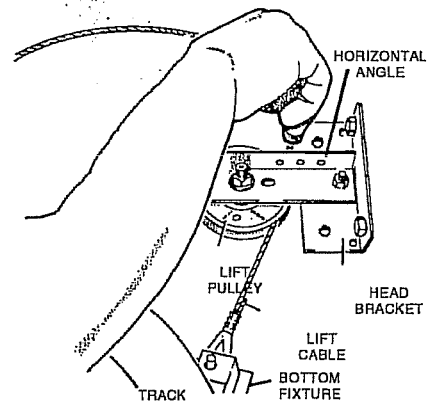

NOTE: Springs should support door equally on both sides.

- Remove locking pliers from tracks.
- Test door operation and readjust spring tension if necessary.
- Too much spring tension will not allow door to stay on floor when closed.
- Insufficient spring tension will make door hard to open.
- Lightly oil hinges and lift cables using 30 wt. oil. Wipe off excess oil.
- If door is painted after installation, extension springs will have to be readjusted to compensate for the added weight.

TORSION SPRING COUNTERBALANCE ASSEMBLY (SCREW-IN PLUGS)

! WARNING

Installation of the Torsion Spring system can be extremely dangerous. All instructions must be strictly followed.

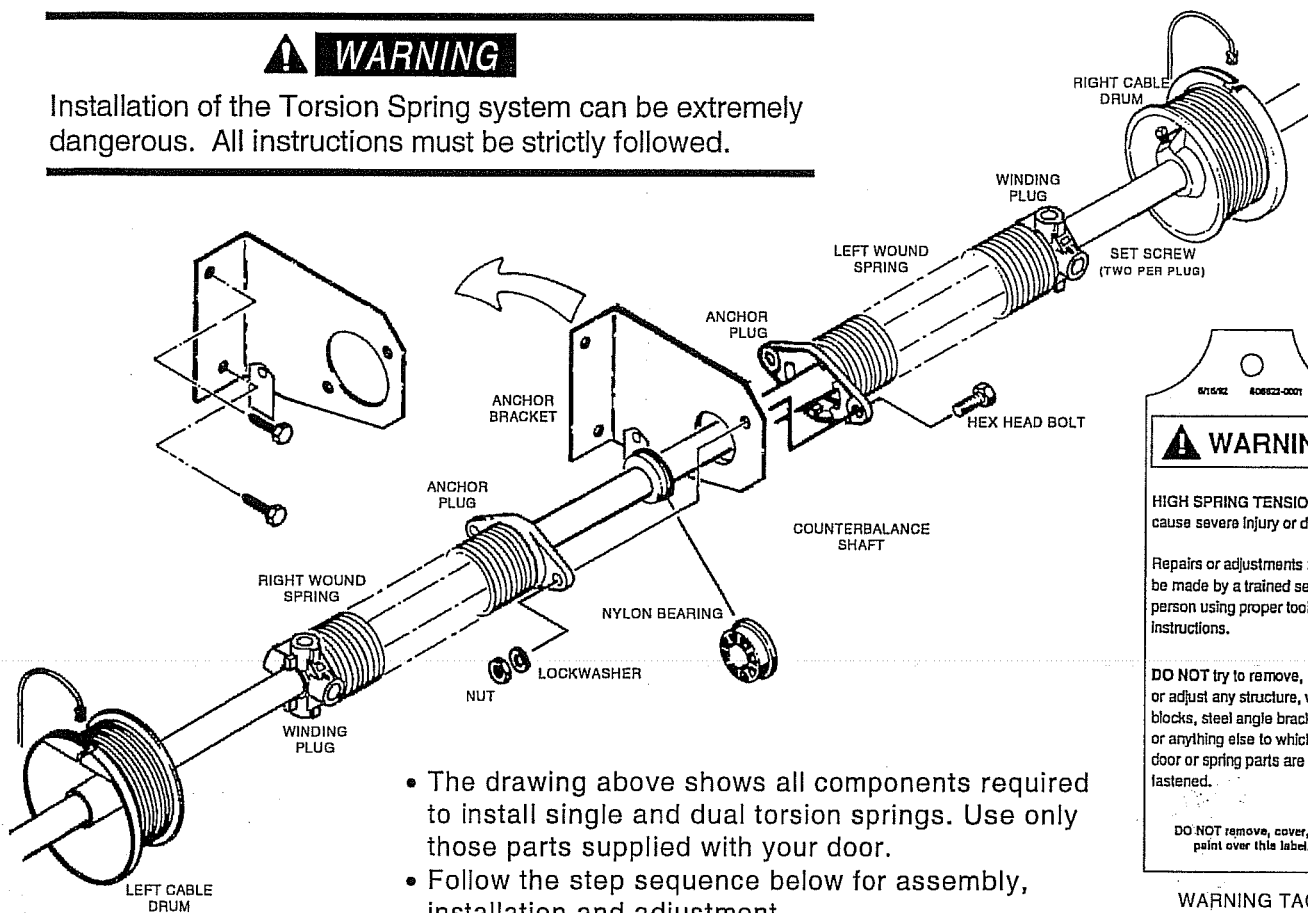

- The drawing above shows all components required to install single and dual torsion springs. Use only those parts supplied with your door.
- Follow the step sequence below for assembly, installation and adjustment.

01/16/02 408622-0001

! WARNING

HIGH SPRING TENSION can cause severe injury or death.

Repairs or adjustments must be made by a trained service person using proper tools and instructions.

DO NOT try to remove, repair, or adjust any structure, wood blocks, steel angle brackets, or anything else to which any door or spring parts are fastened.

DO NOT remove, cover, or paint over this label.

WARNING TAG
408622-0001

TORSION SPRING COUNTERBALANCE (SCREW-IN PLUGS)

STEP 1

- Secure anchor plug(s) to anchor bracket.

NOTE:

- Single torsion spring: If spring is "Left" wound it should be located on right side of anchor bracket. If spring is "Right" wound it should be located on left side of anchor bracket.
- Dual torsion springs: "Left" wound spring located on right side of bracket and "Right" wound spring on left side.

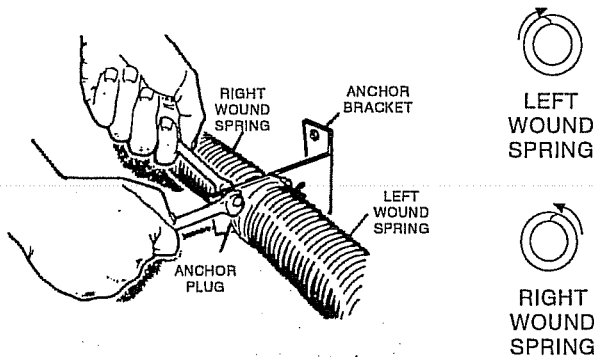

STEP 2

- Slide torsion spring assembly onto counterbalance shaft.
- Install cable drums on shaft. Make sure left and right drums are on correct ends.

NOTE: Drums are marked "R" for right and "L" for left.

- Do not secure setscrews at this time.
- Lay counterbalance shaft assembly on horizontal angles, then insert one end thru headplate with largest amount of sideroom.

CAUTION: Do not insert shaft far enough to pull opposite end off its horizontal angle. Go to opposite end and insert shaft thru remaining headplate. For double wide doors two people are recommended.

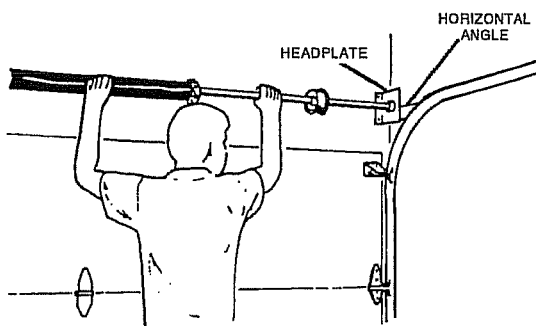

STEP 3

- Raise anchor bracket up to header until counterbalance shaft is level or slightly above.

NOTE: Anchor bracket must be mounted so that center of shaft does not sag below level.

- SINGLE SPRINGS - Locate winding plug near centerline of door.
- DUAL SPRINGS - Locate anchor bracket near centerline of door.

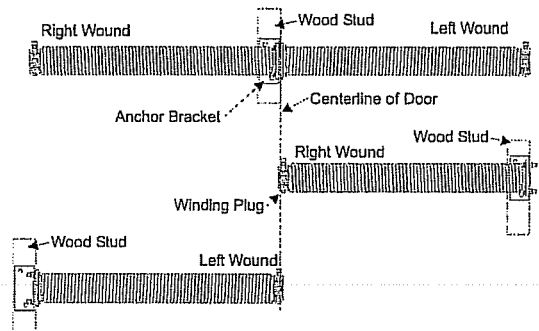

- Secure anchor bracket to stud using 5/16 x 2-1/2" screws in 3/16" pilot holes.

WARNING

Anchor brackets will be under high spring tension and must be securely fastened to a structurally sound wood member or the bracket can break loose and cause severe personal injury.

Anchor into wood stud or structurally sound member. If you have 1/2" drywall between anchor bracket and wood studs, 2-1/2" lag screws should be used.

TORSION SPRING COUNTERBALANCE (SCREW-IN PLUGS)

STEP 4

- Route left side lift cable up to cable drum and insert into cable slot.
- Wind lift cable onto cable drum until all slack is removed and install locking pliers on shaft with handles against ceiling or header.
- Position right cable drum against right headplate and secure setscrews.

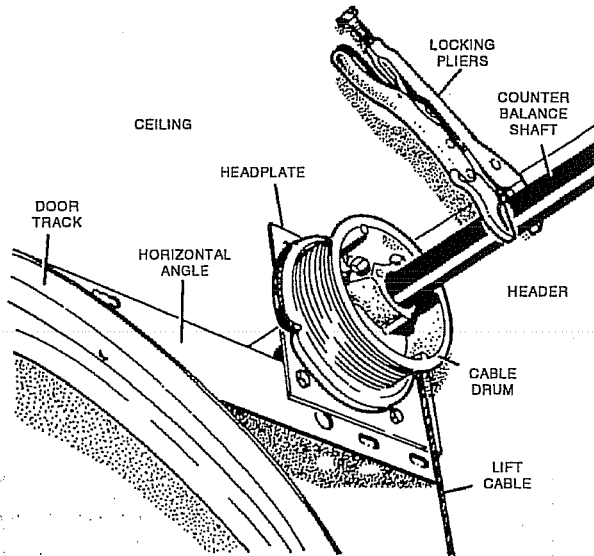

STEP 5

- Route right side lift cable up to cable drum and insert into cable slot.
- Wind lift cable onto cable drum until all slack is removed.

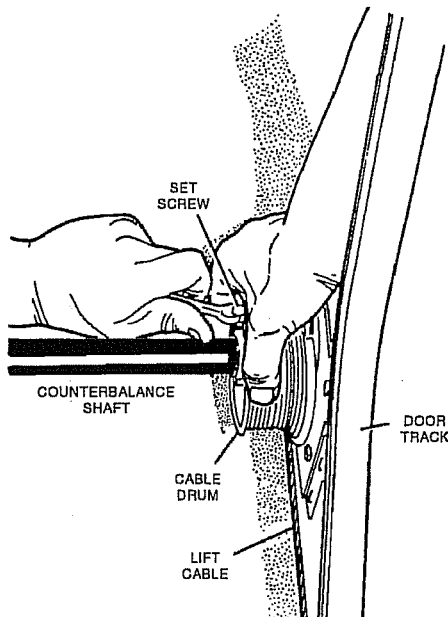

STEP 6

- Check the following before attempting to wind torsion springs:
 - Lift cables secure at bottom fixtures.
 - Lift cables routed unobstructed to cable drums.
 - Lift cables correctly installed and wound onto cable drums.
 - Lift cables are taut.
 - Cable drums are against headplates and setscrews are tight.
 - Torsion spring(s) are installed correctly.
 - Spring tangs fully seated in plugs.

! WARNING

Winding torsion springs is an **EXTREMELY DANGEROUS** procedure and should be performed by a trained technician or a mechanically experienced person using proper tools and following these instructions.

Should you elect to perform this procedure:

1. Read winding instructions thoroughly.
2. Make sure you understand procedure.
3. Follow the instructions carefully.
4. Wear safety glasses.
5. Use only the winding bars included with the door and described in the "Tools Needed" section. **DO NOT SUBSTITUTE** with screwdrivers, pipe, etc. Other tools may fail and cause serious personal injury.
6. Door must be closed when winding or making any adjustments to torsion spring(s).
7. Sound footing is required. Before attempting to wind torsion spring(s) make sure stepladder is sturdy and positioned correctly.

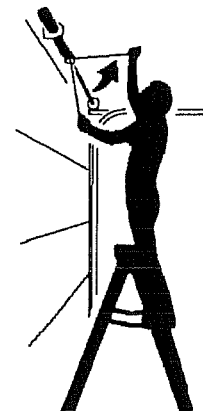

NOTE: Clamp locking pliers to flat portion of door track just above door. This will prevent door from rising quickly once torsion spring winding is complete.

TORSION SPRING COUNTERBALANCE (SCREW-IN PLUGS)

STEP 7

- Draw a chalk line horizontally along the center of the spring coil. As spring is wound, chalk mark will create a spiral. These can be counted to determine the number of turns on the spring.

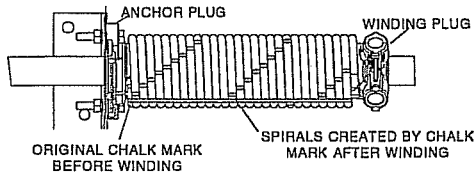

STEP 8

- Insert a winding bar into winding plug and rotate plug 1/4 turn in the direction shown.
- Insert second winding bar into plug, take up torque load and remove first winding bar.

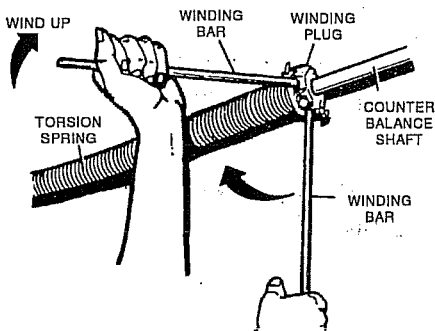

! WARNING

DO NOT remove a winding bar from winding plug until a second bar has been fully seated in plug and torque load has been assumed.

- Continue winding torsion spring until spring is wound the required number of turns.

6 Foot high doors - 6 1/2 turns
 7 Foot high doors - 7 1/2 turns
 8 Foot high doors - 8 1/2 turns

STEP 9

- After winding spring, keep winding bar fully seated in plug.
- Secure winding plug setscrews and remove winding bar.
- Remove locking pliers from counterbalance shaft.
- If dual torsion springs are used, wind remaining spring the same as the first.
- Remove locking pliers from door track.
- See Step 12 for adjustment.

STEP 10

! WARNING

If horizontal tracks are set too far apart at rear, door may fall from tracks resulting in serious personal injury. Raise door slowly so that distance between tracks can be checked.

- Raise door slowly. Watch top track rollers and horizontal tracks.
- Check spacing between ends of door and tracks. Maintain 1/2" clearance.
- If tracks are set too far apart, lower door and make necessary adjustments.
- Cut sway braces from perforated angle (not supplied) and install using hex head bolts (not supplied).

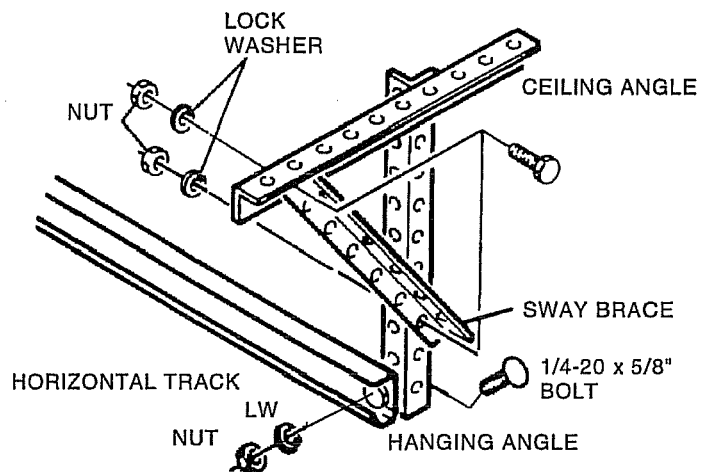

TORSION SPRING COUNTERBALANCE

FINAL ADJUSTMENTS

STEP 11 SCREW-IN PLUGS

- Raise door to check spring tension.
 - Too much spring tension will not allow door to close fully.
 - Insufficient spring tension will make door hard to open.
- Readjust spring tension as required. If tension has to be readjusted, be sure to insert a winding bar into winding plug and assume radial torque load before loosening setscrews.
- Observe all previous WARNINGS.
- Adjust spring tension in 1/4 turn increments.
- Use locking pliers shown in Step 5 before adjusting single spring doors.
- Verify that the counterbalance shaft turns freely in the anchor plug and that the spring tangs do not come in contact with the shaft.

STEP 12

- Lightly oil springs, hinges and lift cables using 30 wt. oil. Wipe off any excess oil.
- If door is painted after installation, torsion springs will have to be readjusted to compensate for the added weight.

NOTES

- With door closed, loosen center and bottom jamb bracket track bolts.
- At bottom of door, push vertical track as far forward as possible and secure track bolt at bottom jamb bracket.
- Resecure track bolt at center jamb bracket.
- Adjust stop molding against outside face of door and secure.

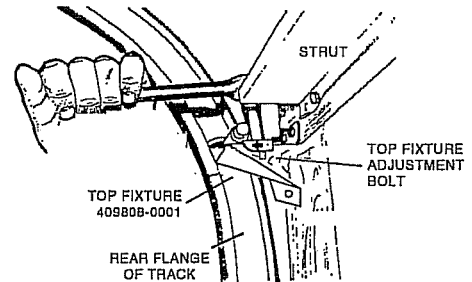

- Adjust top fixtures until top section is flush against stop molding and track rollers are against rear flange of track.

ARMORTITE Counterbalance Instructions

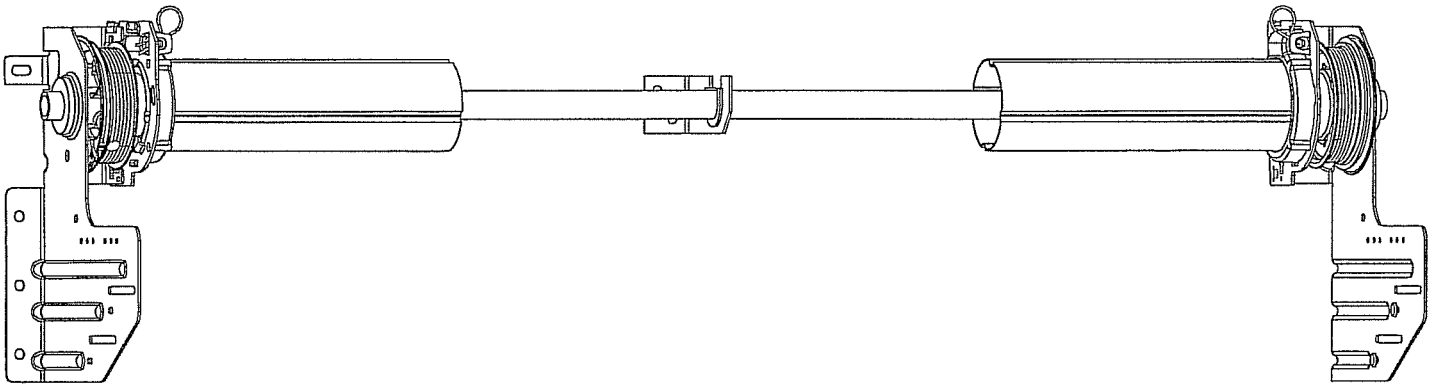

Figure A. Armortite Counterbalance Assembled
(Two-Spring System Shown)

Parts List

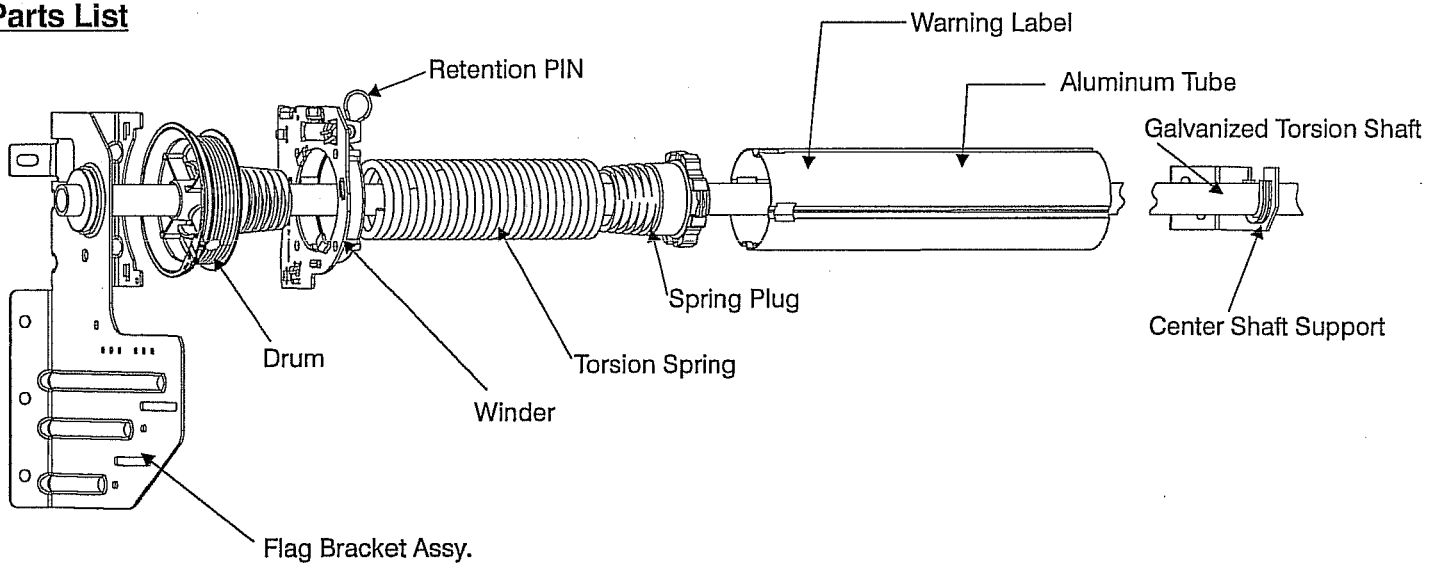

Figure B. Diagram of Parts

Standard Lift Configuration Assembly

Step 1. Assembly of Parts on the Shaft

- A. Slide counterbalance on the shaft as shown in Figure C-1. Standard single spring systems will use left-hand Armortite assemblies. For dual spring systems, verify the left-hand Armortite assembly is matched to the left side of the door and the right hand Armortite assembly is matched to the right side of the door. Drums and winders are labeled "L" and "R".
- B. For single spring systems install a corresponding drum on the opposite side of the shaft. (Figure C)
- C. Install counterbalance shaft in to the headplate bearings along with the Armortite assembly as shown in Figure C-1.
- D. Slide left and right drums as far outward as possible so that they are touching the left and right one-piece flag brackets bearing respectively.
- E. Install the shaft support above the center of the door and position it so that the counterbalance shaft is level. (See Figure D)

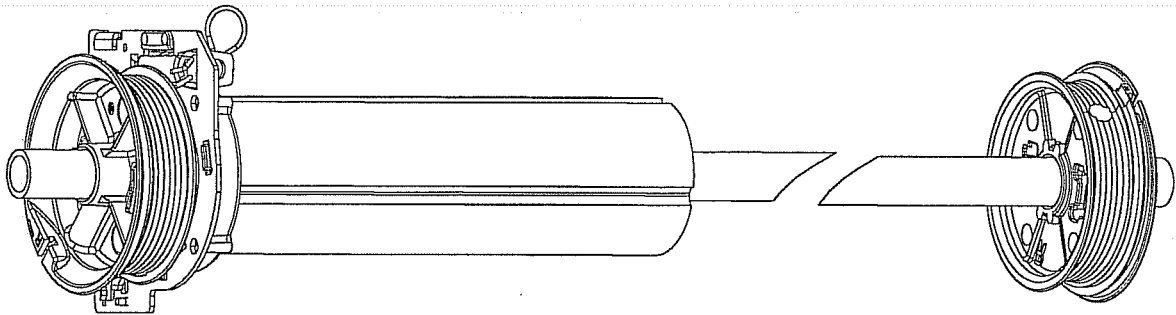

Figure C. Diagram of Parts assembled on Shaft

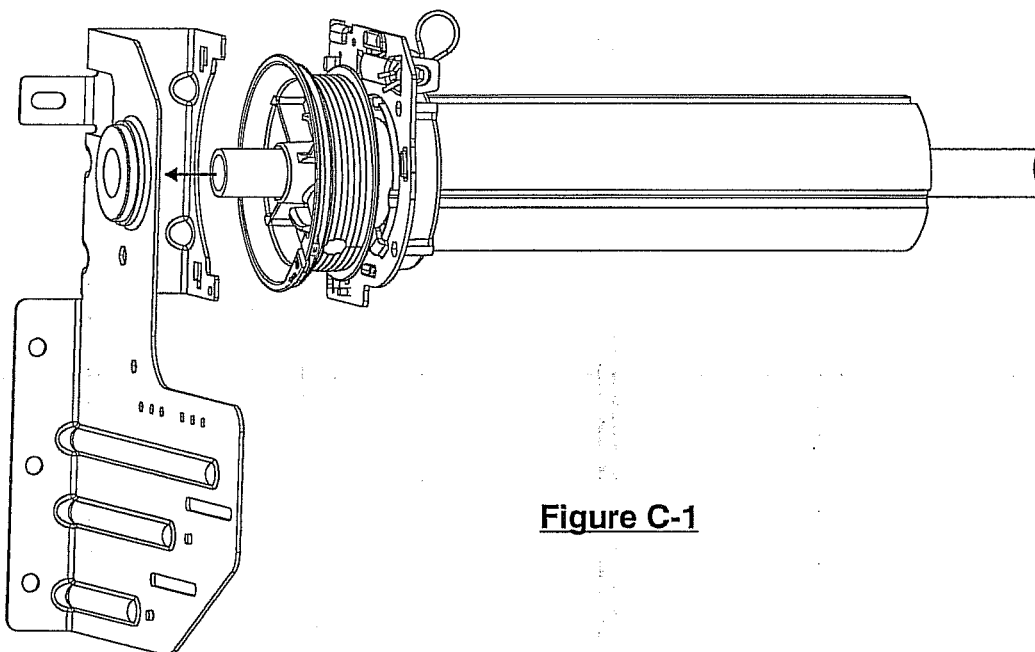

Figure C-1

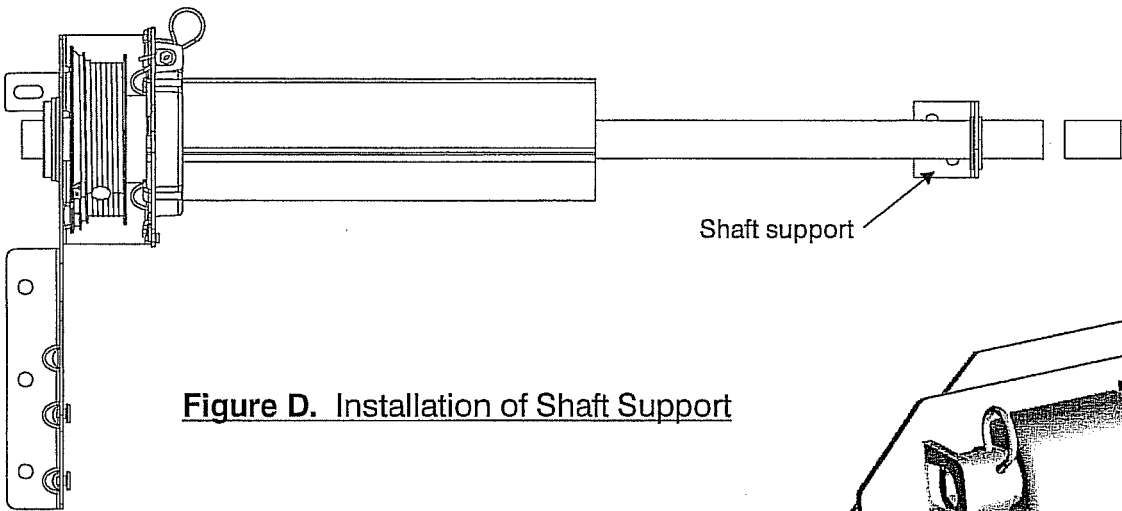

Figure D. Installation of Shaft Support

Step 2. Final Assembly of Components

- A. Remove alignment screw from winder plate. (See Figure E)
- B. Install winder plate to header plate by inserting tabs into slots then twist and slide winder downward to properly seat it in place.
NOTE: Verify that all winder plate tabs are properly engaged in the appropriate slots of the header plate. See Figure F.
- C. Install self-tapping alignment screw (that was previously removed) through alignment hole in winder plate and header plate. See Figure E.
- D. Slide aluminum tube out from the winder plate and uncover the spring. Lubricate the spring and wipe off the excessive amount of oil. Slide the tube back over spring.
- E. Attach the left hand cable to the left hand drum and rotate the drum so that the cable is taut.
- F. Rotate aluminum tube by hand $\frac{1}{2}$ to $\frac{3}{4}$ turns in a downward direction (See Figure G), then insert the aluminum tube completely into the winder. When completely inserted, the spring tension created when rotating the aluminum tube should cause the tube to automatically engage and lock the aluminum tube to the winder plate.
- G. Verify that aluminum tube is properly locked to the winder plate by attempting to pull it away from the winder plate.
- H. For two-spring counterbalances, repeat steps A-G for the opposing (Right) Side.

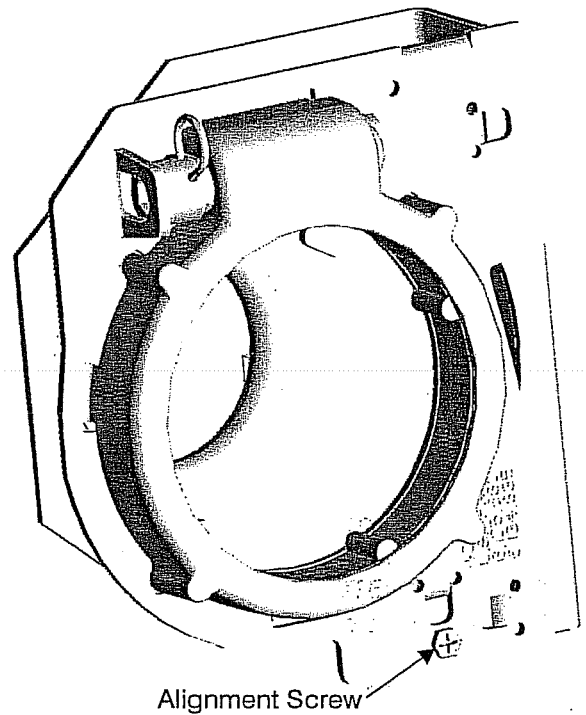

Figure E.

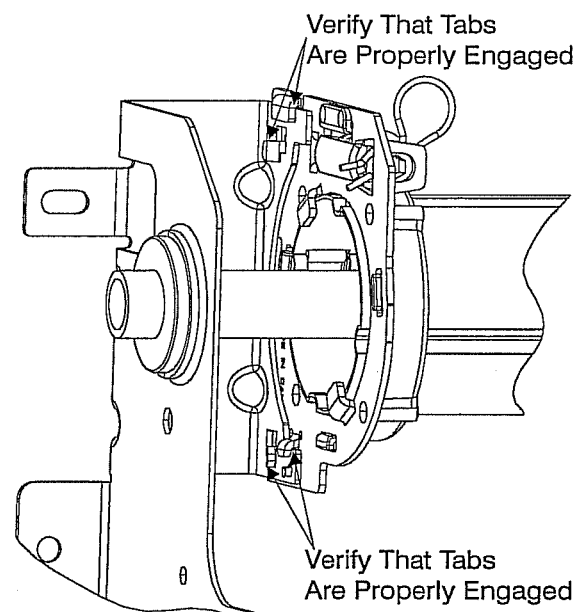

Figure F.

Step 3. Set Screw and cable

- A. Tighten the left drum set screw with a 3/16" Allen hex wrench.
- B. Attach the right cable to the right hand drum and rotate the drum so that the cable is taut. Tighten the set screw on the right hand drum.

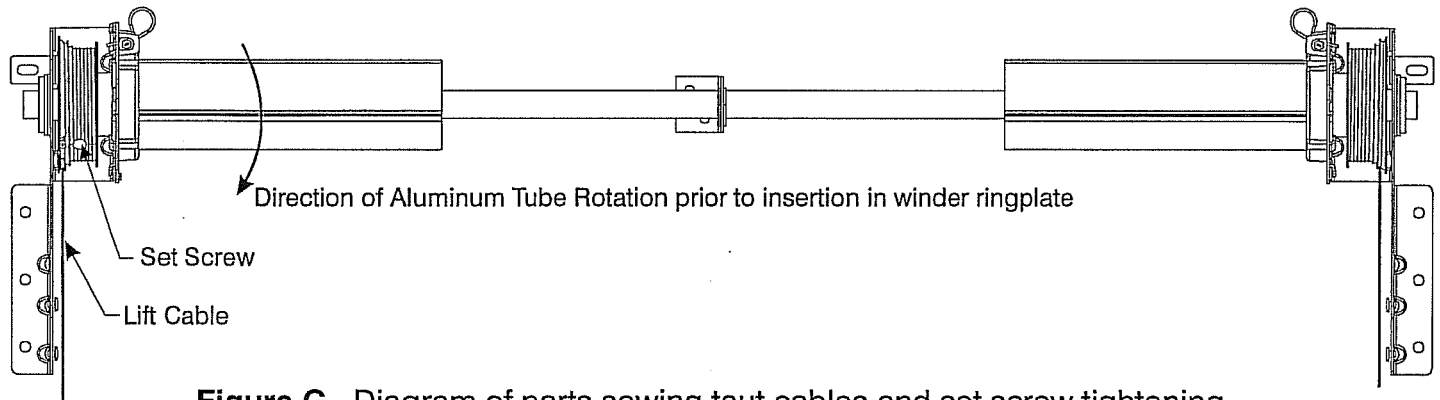

Figure G. Diagram of parts showing taut cables and set screw tightening

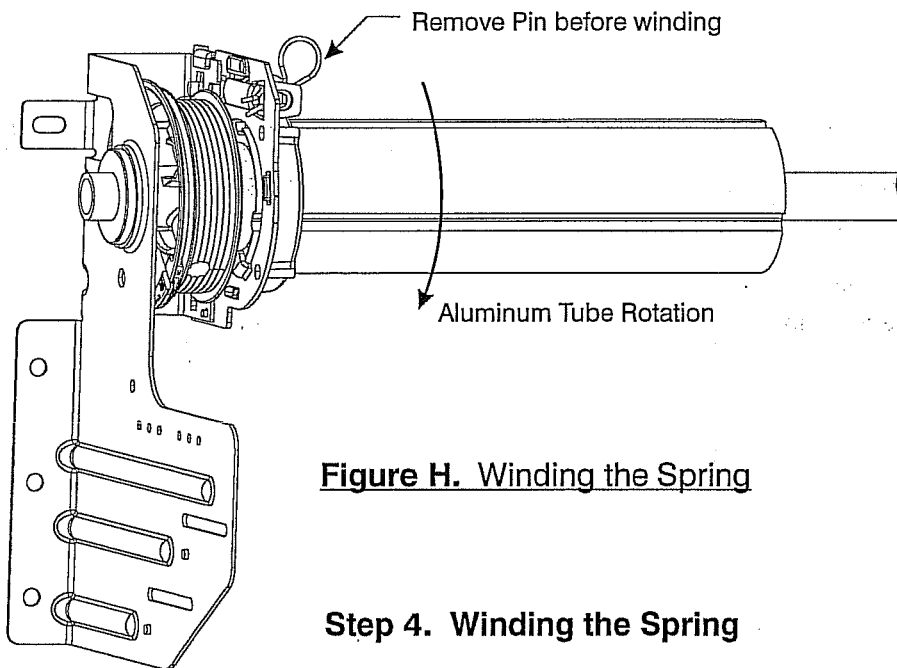

Figure H. Winding the Spring

Step 4. Winding the Spring

- A. Remove Retention Pin from winder.
- B. Using a hand drill with a 5/16" Allen hex bit (DO NOT USE AN IMPACT WRENCH), turn the left winder clockwise so that the aluminum tube rotates the specified direction (See Figure H) and a specified number of times (to keep track of the number of rotations, count the number of times the black stripes on the aluminum tube warning label rotates).
- C. For a two-spring counterbalance system, repeat steps A and B for the right side and wind both springs equal number of turns.
- D. Verify door is balanced correctly. Any necessary adjustments can be made by adding more winds or reversing the direction of the drill, and unwinding the spring. For double counterbalance systems, any adjustments should be made equally to both springs.

Step 5. Refer to Figure I

A. Once door is balanced, re-install Retention Pin on winder.

WARNING: Install Retention Pin as you see in Figure I & Figure F. Both ends of the Retention Pin must pass through the hole in the Winder plate. Improper Pin installation could result in loss of Pin during operation, and subsequent loss of spring tension.

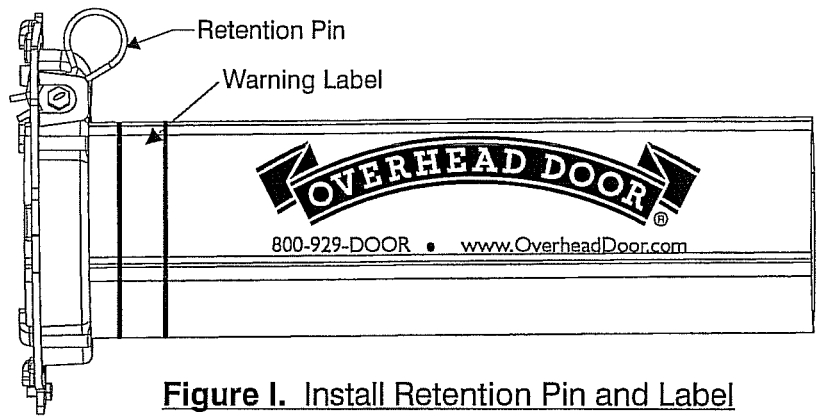

Figure I. Install Retention Pin and Label

Low Headroom Torsion Front Configuration

Installation of this configuration is similar to the standard lift configuration with the following difference:

A. Low headroom head-plates are used to mount the counterbalance. (Note that cables are spooled from the back of the drum)
See Figure J.

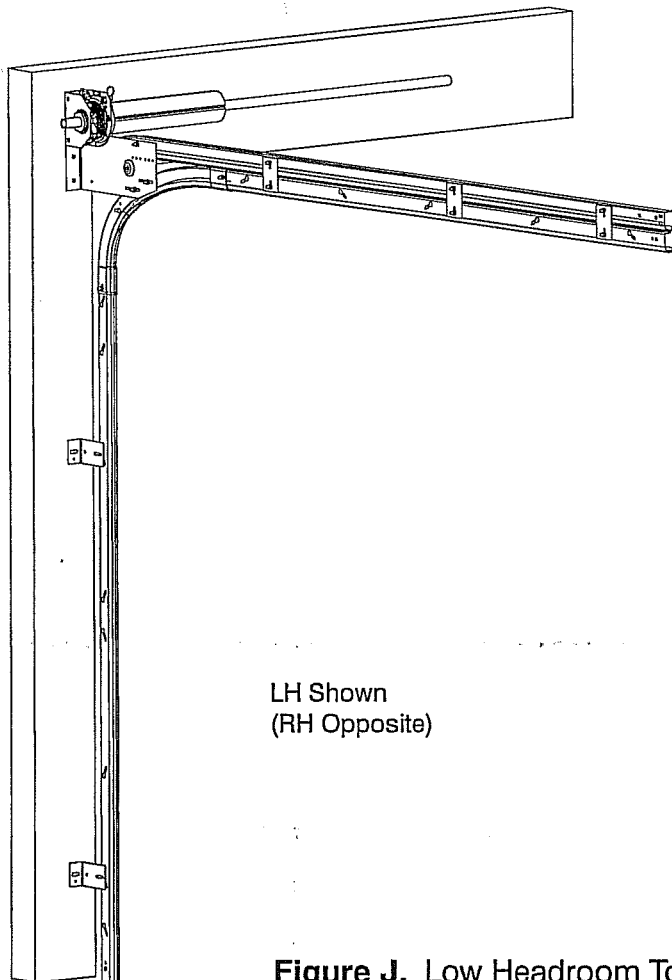
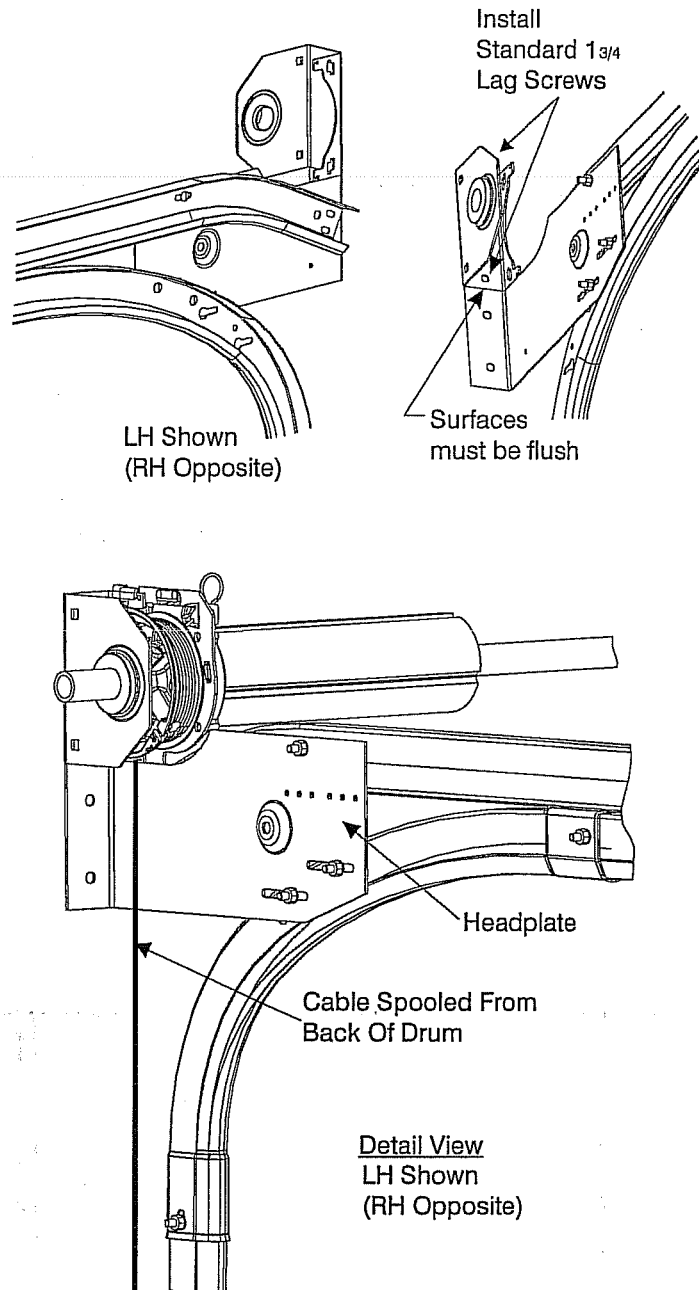
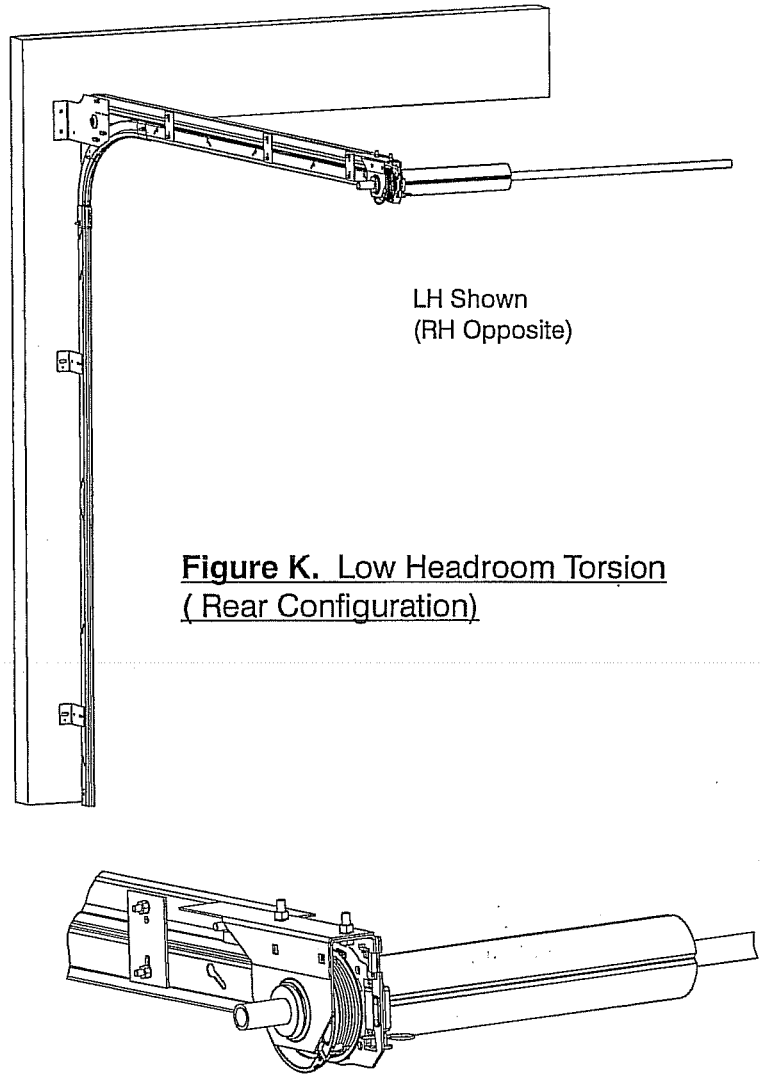
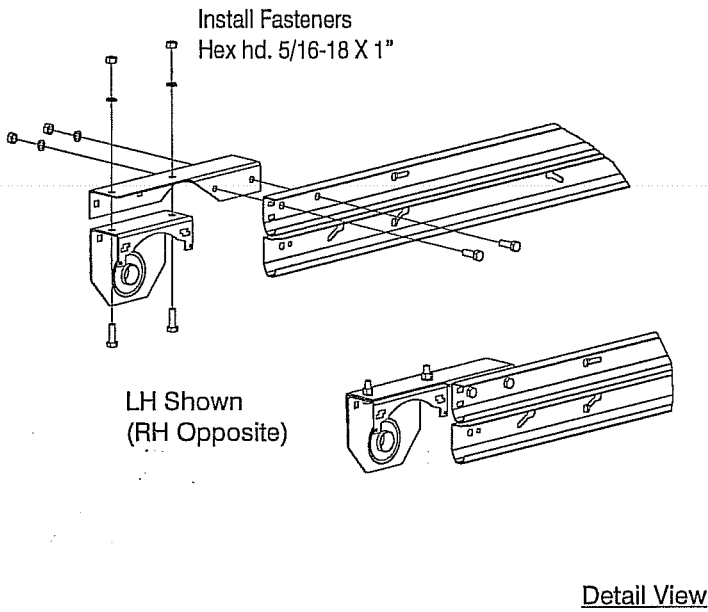

Figure J. Low Headroom Torsion Front Configuration

Low Headroom Torsion Rear Configuration

Installation of this configuration is similar to the standard lift configuration with the following notable differences:

- A. Low headroom headplates and low headroom torsion rear brackets are used to mount the counterbalance at the rear of the horizontal track.
- B. Suitable location for center shaft support will need to be found.



NOTES

LIMITED WARRANTY

The authorized distributor of OVERHEAD DOOR CORPORATION products whose name appears below ("Seller") warrants the product sold under this warranty to be free from defects in material and workmanship under normal use and service. This warranty extends only to the original consumer ("Buyer"), and expires one year after the date of installation.

Seller's sole obligation under this warranty is limited to repairing or replacing any parts which shall be determined by Seller to be defective, and is conditioned upon Buyer giving notice of any such defect to Seller within the warranty period. If Seller concludes that repair or replacement is necessary, Seller will commence work within a reasonable time after the decision to repair or replace is made.

This warranty does not apply to any product which has been altered or repaired by any person not authorized by the Seller, or which has been subjected to misuse, neglect or accident.

THERE IS NO WARRANTY OF MERCHANTABILITY, WARRANTY OF FITNESS FOR ANY PARTICULAR PURPOSE OR ANY OTHER IMPLIED WARRANTY BEYOND THE ONE-YEAR PERIOD DESCRIBED ABOVE. SELLER SHALL NOT BE LIABLE FOR INCIDENTAL OR CONSEQUENTIAL DAMAGES NOR FOR ANY FURTHER LOSS WHICH MAY ARISE IN CONNECTION WITH ANY CLAIM.

This warranty gives you specific legal rights, and you may also have other rights which vary from state to state. Some states do not allow limitations on how long an implied warranty lasts and some states do not allow the exclusion or limitation of incidental or consequential damages, so the above limitations or exclusions may not apply to you.

Seller has not established any informal dispute settlement procedure of the type described in the Magnuson-Moss Warranty Act. Claims under this warranty must be made in writing to the Selling Distributor whose name and address appears below within the applicable warranty period. (Proof of purchase and identification as the original purchaser may be required.)

Inquiries to the Seller concerning this warranty should be directed to: