

Automated Vehicular Boom Gate System

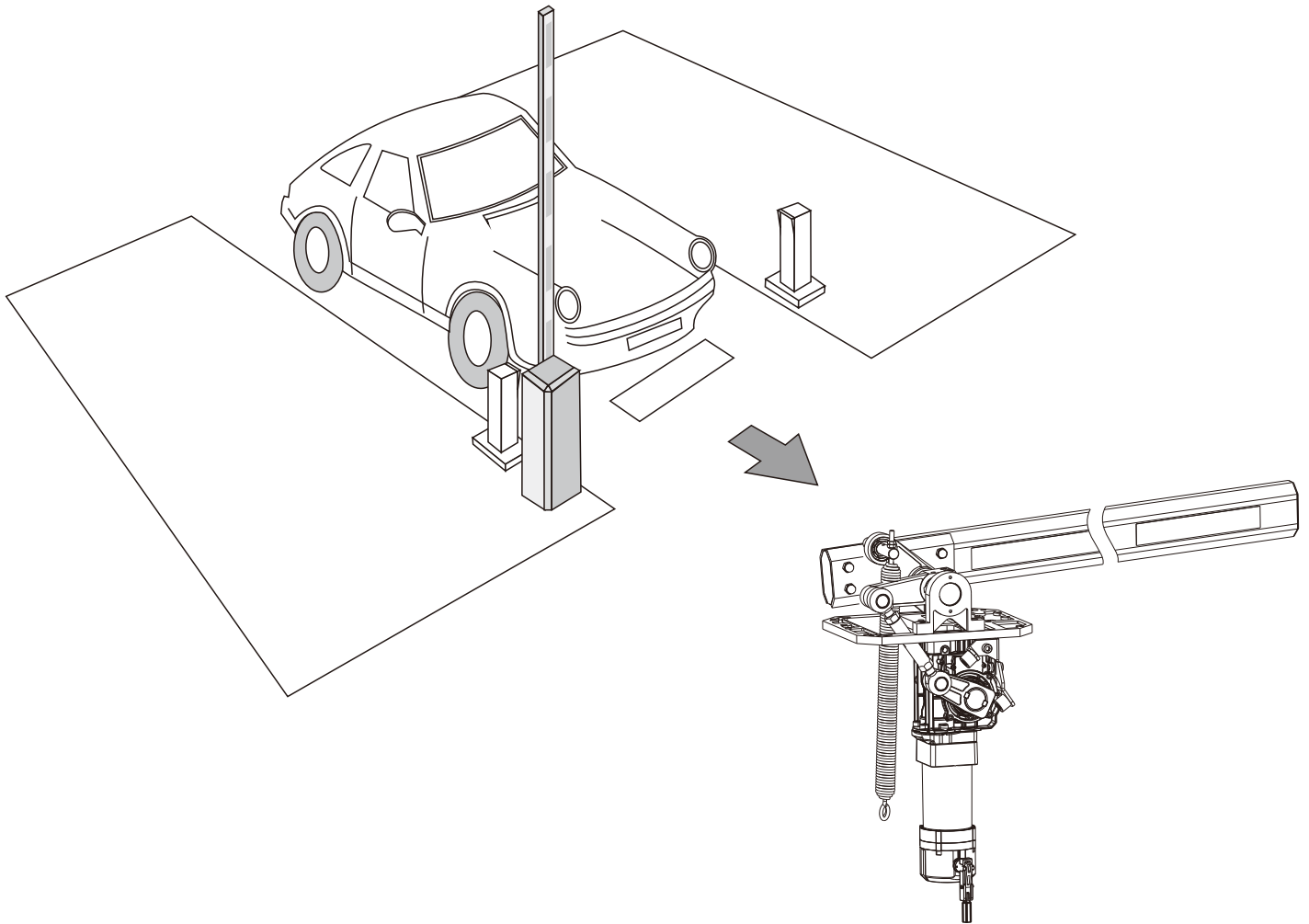

Installer and User's Manual
Please read carefully before using



Automatic Boom Gates are not for Pedestrians!

Automatic gate openers are designed for vehicular traffic. They are powerful and can cause serious bodily injury or death. Accordingly, direct all pedestrian traffic to a separate walk-through gate.

1. Before starting installation and operation or maintenance, cut off power supply.
2. The product must be earthed, And an earth leakage breaker is necessary on the power supply.
3. As for electric cable type and section, we suggest to use the cable type of <HAR> with minimum section of 2.0mm²
4. Do not change the original inside wiring.
5. If power failure, please switch off the power supply first, then open the door and rotate the handle on the motor manually to open the boom completely.
6. Keep the automatic control (push-button, remote control, etc) out of the reach of children. The control system must be installed at a minimum height of 1.5m from the ground surface.
7. Use transmitters or button only where you can see the gate clearly.
8. Never open the door or the cover of the cabinet when the machine is working.
9. Do not permit children to play on or around a gate.



Automatic Gates are Not for Pedestrians!

Automatic gate openers are designed for vehicular traffic. They are powerful Accordingly, direct all pedestrian traffic to a separate walk- through gate.

A. Technical specifications

AC series

Power supply	220VAC 50Hz / 110VAC 60Hz
Motor's power:	120WAC
Max length of Boom:	6M 1.6S(for 1-2M) 4S(for 3-4M)
Time of Up/Down:	6S(for 5M)
Working environment:	-20°C--50°C
Protection class:	IP55
Noise:	<65db

DC series

Power supply	220VAC 50Hz / 110VAC 60Hz
Motor's power:	80WDC
Max length of Boom:	6M 1.6S(for 1-2M) 4S(for 3-4M)
Time of Up/Down:	6S(for 5M)
Working environment:	-20°C--50°C
Protection class:	IP55
Noise:	<65db

BS-TI

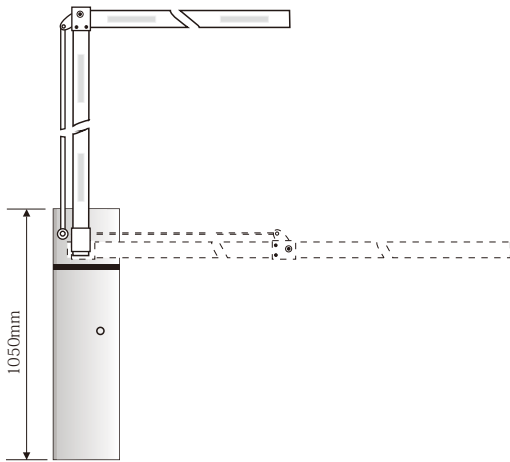

BS-TII

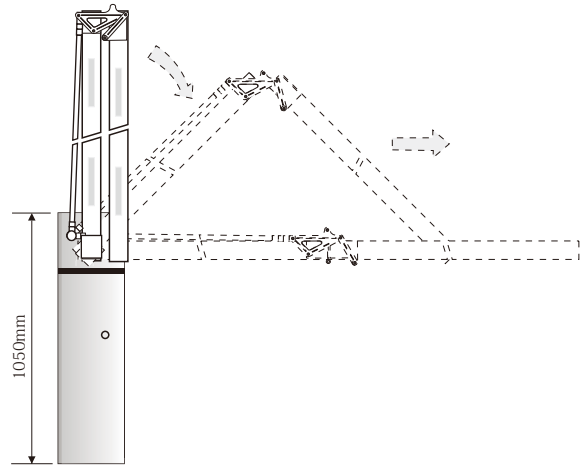

BS-TIII(A)

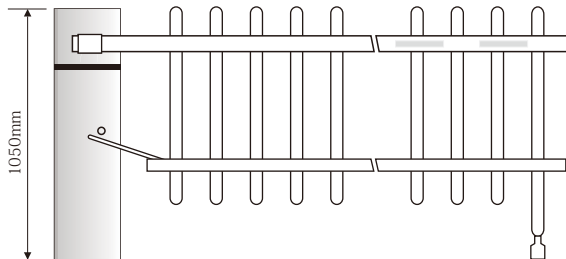

BS-TIII(B)

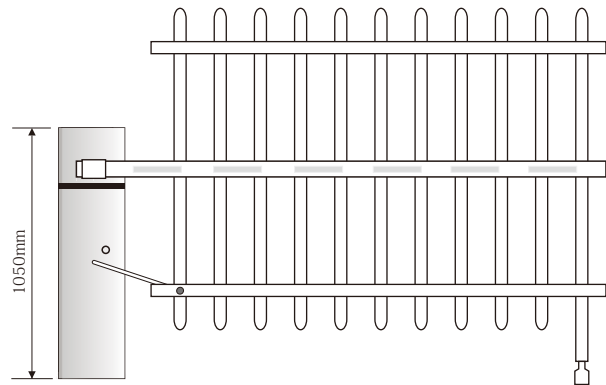

B. Installing and adjusting

1. Install the machine on the ground (Fig.1)

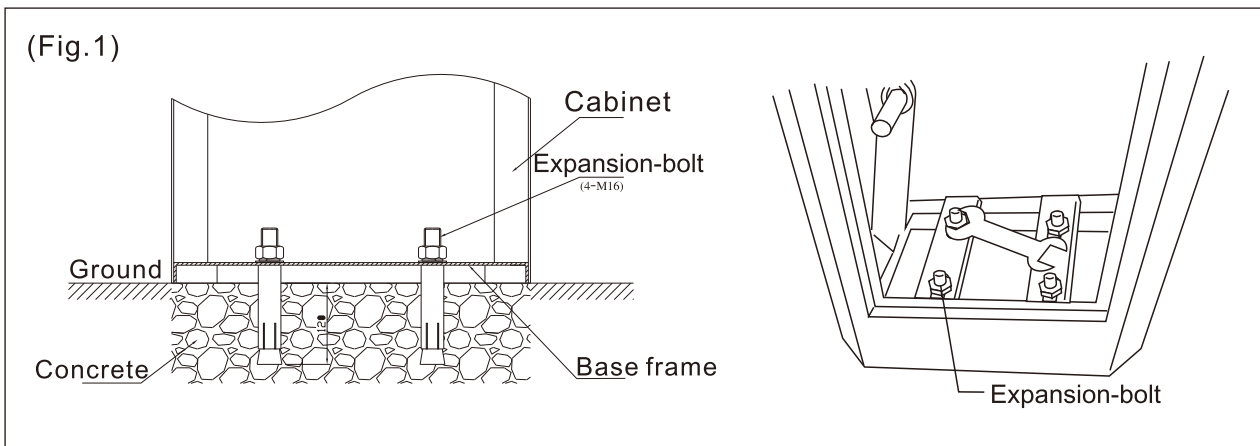

2. Install boom (Fig.2)

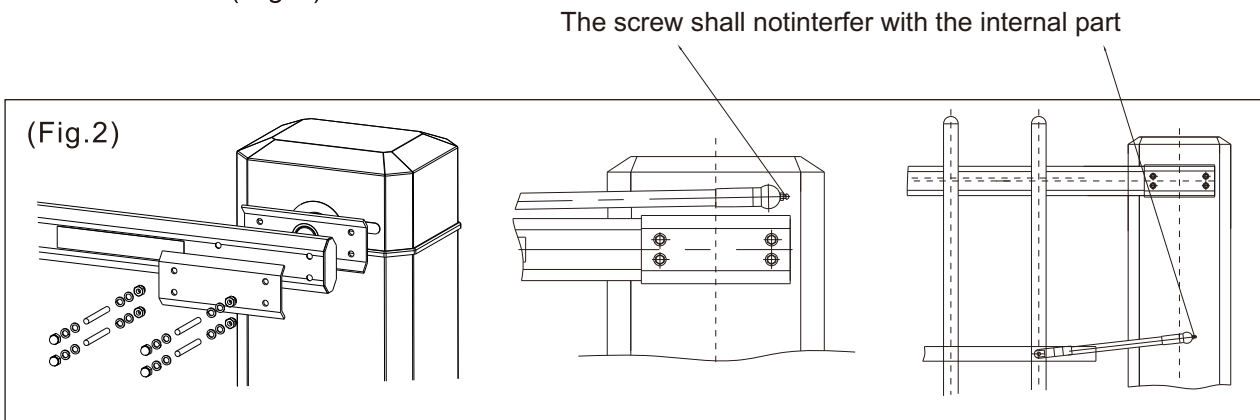

3. Adjust the limit position

Refer to the corresponding Control Unit Instructions

C. Adjust the vertical and horizontal line of the Boom. _____

C.1 Boom need to be shorter (Fig.3) (Fig.4)

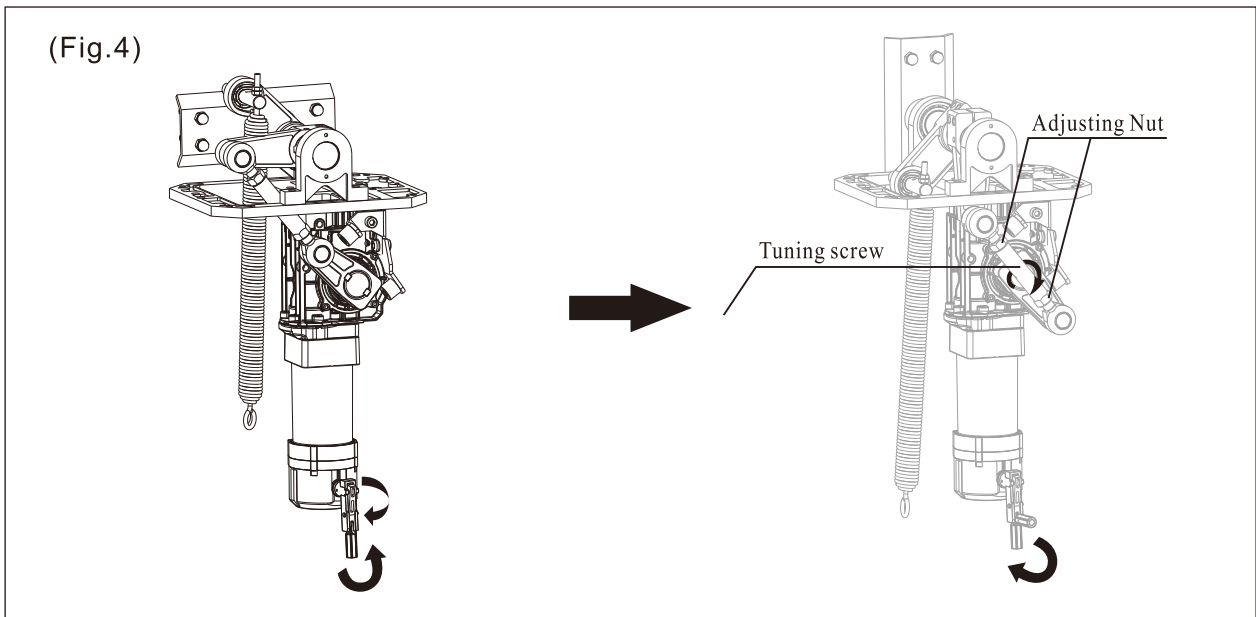
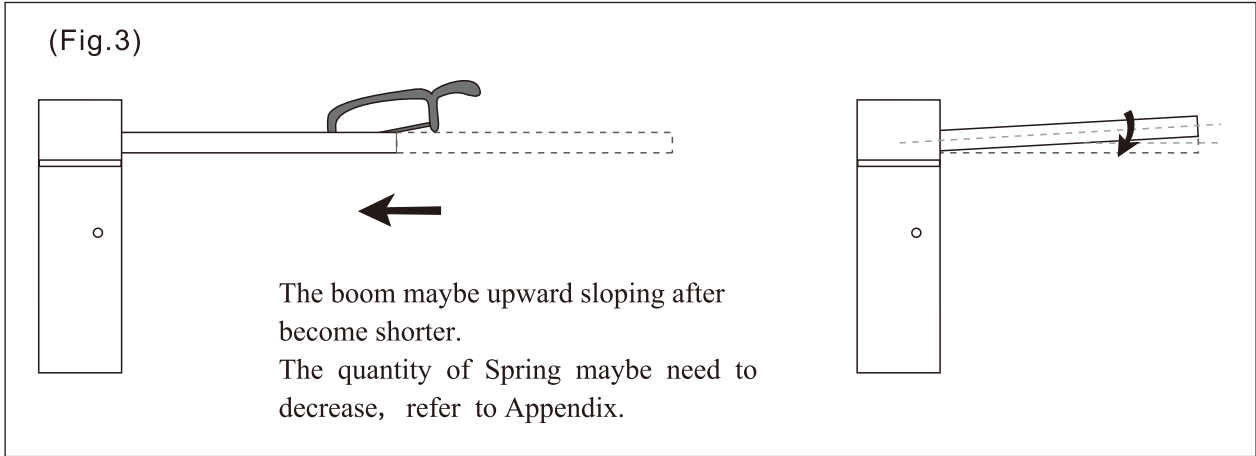

Put up the boom to perpendicularity by hand.

1. Loosen the Adjusting Nuts.
2. Adjust the Tuning Screw and see the Boom, if the Boom is perpendicular to the ground when it is open, tighten the Adjusting Nuts.

C.2 Boom need to be longer (Fig.5) (Fig:6)

(Fig.5)

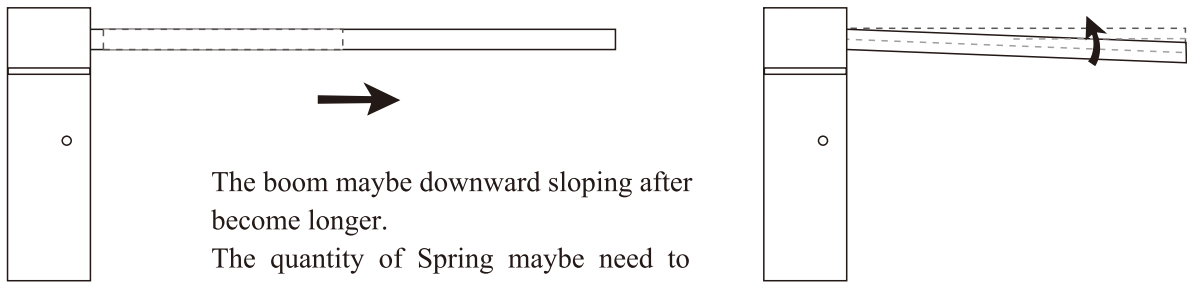

The boom maybe downward sloping after become longer.
The quantity of Spring maybe need to add, refer to Appendix.

(Fig:6)

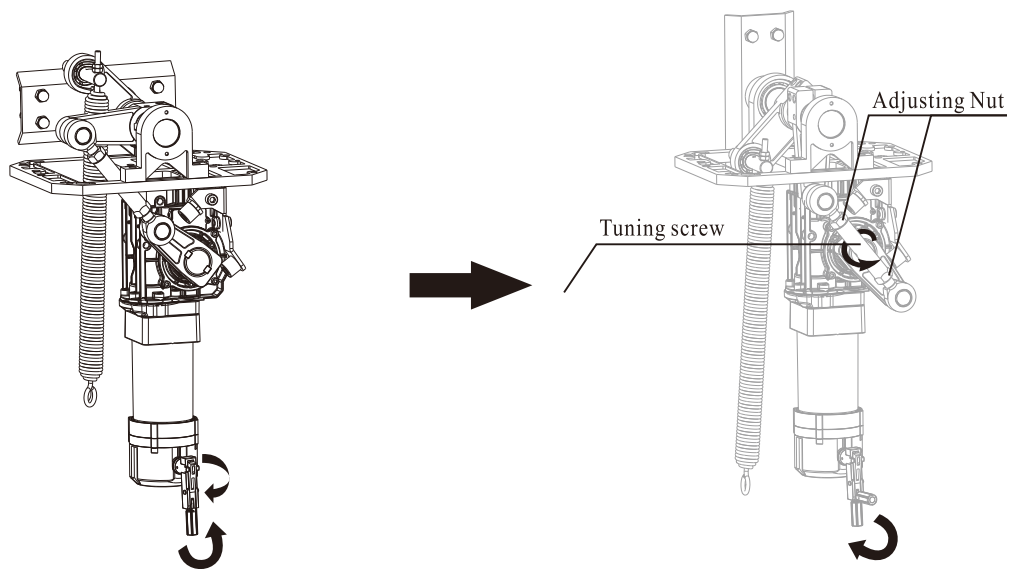

Put up the boom to perpendicularity by hand.



Adjust the balance of the spring with boom.

The springs have been already adjusted to balance with the boom. If the length of boom need to be changed, the springs should be re-adjusted.

See the Appendix and Fig3/Fig4/Fig5/Fig 6

- 1.Loosen the Adjusting Nuts.
- 2.Adjust the Tuning Screw and see the Boom, if the Boom is perpendicular to the ground when it is open, tighten the Adjusting Nuts.

D. Electrical safety devices (Fig.7)

- The BARRIERS limit switches, motor and control unit are already connected up.
- Only the photo cells, the loop detector and the supply voltage have to be connected up in installation.

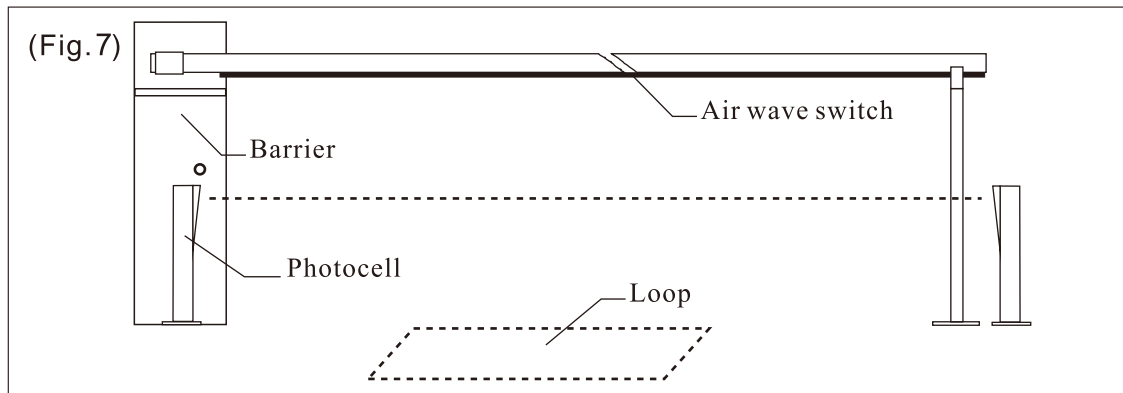

Appendix

Table of spring quantity and size with Boom's length

Model	Boom Length	Quantity of Spring	Spring's size
106 206 806 906	3-4m	1	φ5×440mm
	4.5-5m	2	φ5×440mm
	6m	2	φ5×440mm φ6×440mm
T-I/II-206 T-I/II-806 T-I/II-906	3-4m	1	φ5×440mm
	4.5m	2	φ5×440mm
	5m	2	φ5×440mm
	6m	2	φ5×440mm φ6×440mm
T-III(A)-206 T-III(A)-806 T-III(A)-906	3-4m	1	φ6×440mm
	4-4.5m	2	φ5×440mm φ6×440mm
	4.5-5m	2	φ6×440mm
T-III(B)-206 T-III(B)-806 T-III(B)-906	3-4m	2	φ5×440mm φ6×440mm
	4-4.5m	2	φ6×440mm
	4.5-5m	2	φ6×440mm
306	3-4m	1	φ5×440mm
	4.5m	2	φ5×440mm
	5m	2	φ5×440mm
	6m	3	φ5×440mm
T-I/II-306	3-4m	1	φ5×440mm
	4-4.5m	2	φ5×440mm
	4.5-5m	2	φ5×440mm
T-III(A)-306	3-4m	2	φ5×440mm
	4-4.5m	3	φ5×440mm
	4.5-5m	2	φ5×440mm φ6×440mm
	5-6m	4	2×φ5×440mm 2×φ6×440mm
T-III(B)-306	3-4m	3	φ5×440mm
	4-4.5m	2	φ5×440mm φ6×440mm
	4.5-5m	4	2×φ5×440mm 2×φ6×440mm
606	3-4m	1	φ5×440mm
	4.5m	2	φ5×440mm
	5m	2	φ5×440mm
	6m	3	φ5×440mm
T-I/II-606	3-4m	1	φ5×440mm
	4-4.5m	2	φ5×440mm
	4.5-5m	2	φ5×440mm
T-III(A)-606	3-4m	2	φ5×440mm
	4-4.5m	3	φ5×440mm
	4.5-5m	2	φ5×440mm φ6×440mm
T-III(B)-606	3-4m	3	φ5×440mm
	4-4.5m	2	φ5×440mm φ6×440mm
	4.5-5m	3	1×φ5×440mm 2×φ6×440mm